

L O F T™

Note Software Manual

Table of Contents

1 Software Introduction	1
2 Installation Description.....	2
2.1 Operating Environment.....	2
2.2 Installing the Software.....	2
3 Usage Introduction.....	5
3.1 Basic Functions.....	5
3.1.1 Menu	5
3.1.1.1 File	6
3.1.1.2 Import	6
3.1.1.3 Export.....	12
3.1.1.4 Print.....	13
3.1.1.5 Settings.....	13
3.1.1.6 Help	16
3.1.1.7 Mode.....	22
3.1.1.8 Exit	22
3.1.2 Desktop	23
3.1.3 Treasure Chest.....	23
3.1.3.1 Backgrounds.....	24
3.1.3.2 Subjects	26
3.1.3.3 Tools.....	27
3.1.3.4 Shortcuts.....	43
3.1.4 Resource Library.....	43
3.1.5 Image Browser	46
3.1.6 Select.....	48
3.1.6.1 Handwriting.....	50
3.1.6.2 Line.....	56
3.1.6.3 Planar Graph.....	57
3.1.6.4 3D Graph	62

3.1.6.5 Text	63
3.1.6.6 Picture	64
3.1.6.7 Audio/Video	65
3.1.6.8 Compass Graph.....	66
3.1.7 Handwriting	67
3.1.8 Eraser	69
3.1.9 Shape.....	70
3.1.9.1 Geometric Figures.....	71
3.1.9.2 Line.....	73
3.1.9.3 Properties.....	75
3.1.10 Roaming.....	75
3.1.11 Handwriting Recognition.....	76
3.1.12 Cancel	77
3.1.13 Redo	77
3.1.14 Add Page	77
3.1.15 Previous Page.....	77
3.1.16 Page Management.....	77
3.1.16.1 Crescent Mode.....	78
3.1.16.2 Page Ball Mode.....	79
3.1.16.3 Page Grouping.....	80
3.1.16.4 Others.....	81
3.1.17 Next Page.....	83
3.1.18 Shortcuts	84
3.1.19 Others.....	85
3.2 Functions in Modes.....	85
3.2.1 Preparation Mode.....	86
3.2.2 Presenting mode.....	87
3.2.3 Desktop Mode.....	87
3.3 Subject Mode.....	88
3.3.1 Math Mode.....	89
3.3.2.1 Basic Functions.....	89
3.3.2.2 Math Tools	91

3.3.2 English Mode	100
3.3.3 Physics Mode	102
3.3.3.1 Basic Functions.....	102
3.3.3.2 Physics Tools	103
3.3.4 Chemistry Mode.....	104
3.3.4.1 Basic Functions.....	105
3.3.4.2 Chemical Tools	105

1 Software Introduction

Note is a touchscreen-based interactive whiteboard software. The software applies to teaching based on an interactive flat panel. It provides whiteboard functions such as: writing, erasing, commenting, drawing, and roaming. Superior interactive teaching and demonstration experience is achieved based on the interactive multimedia function of the intelligent panel, such as subject-specific tools and multimedia demonstration.

2 Installation Description

2.1 Operating Environment

- Windows 7/8/8.1/10
- Net Framework 4.0 or later
- Microsoft Media Player 10.0 or later
- Flash Player 10 or later
- Microsoft Office 2007 or later

2.2 Installing the Software

Double-click the installation package to decompress it. After decompression, the installation wizard is displayed. See Figure 2-2-1.

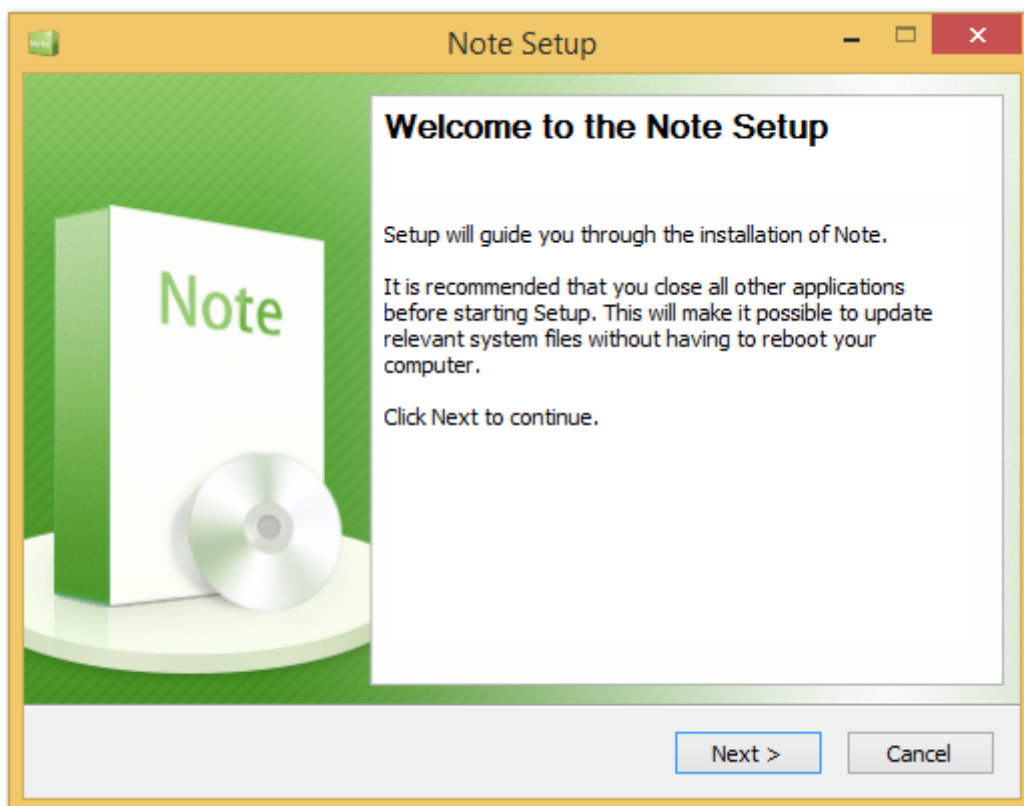

Figure 2-2-1 Installation wizard

Click **Next** to choose install location. See Figure 2-2-2.

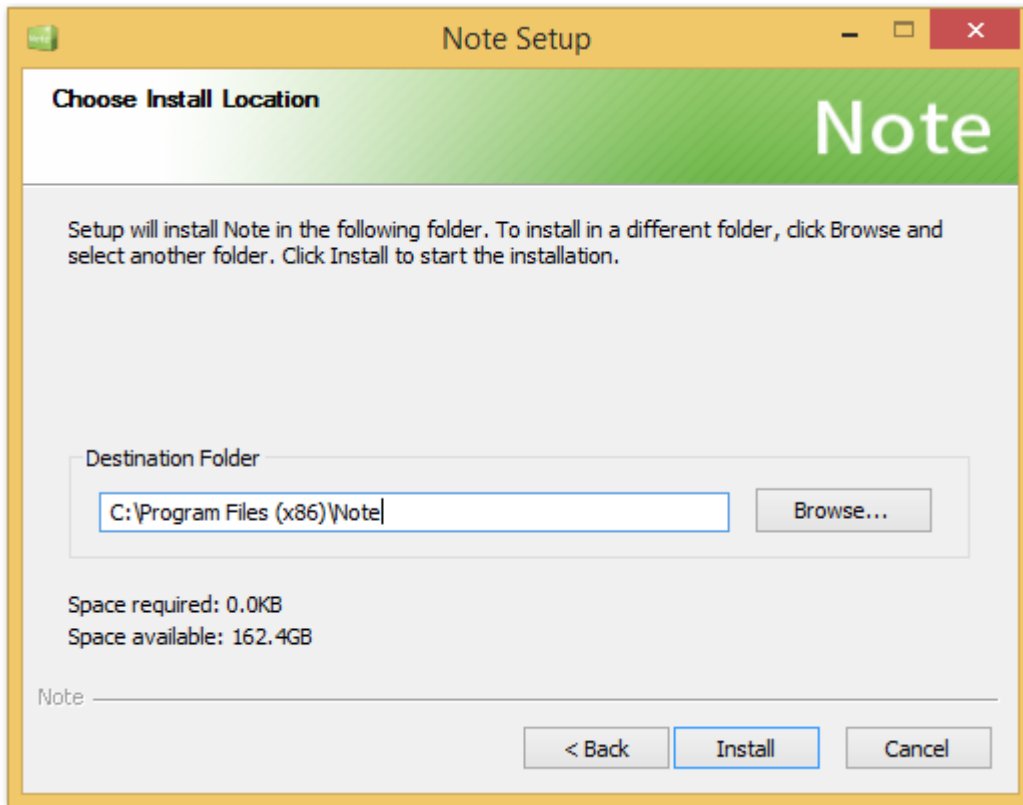

Figure 2-2-2 Choose install location

Click **Browse** to choose another location on your computer to install the Software. Then click **Install** to display the installation interface. See Figure 2-2-3

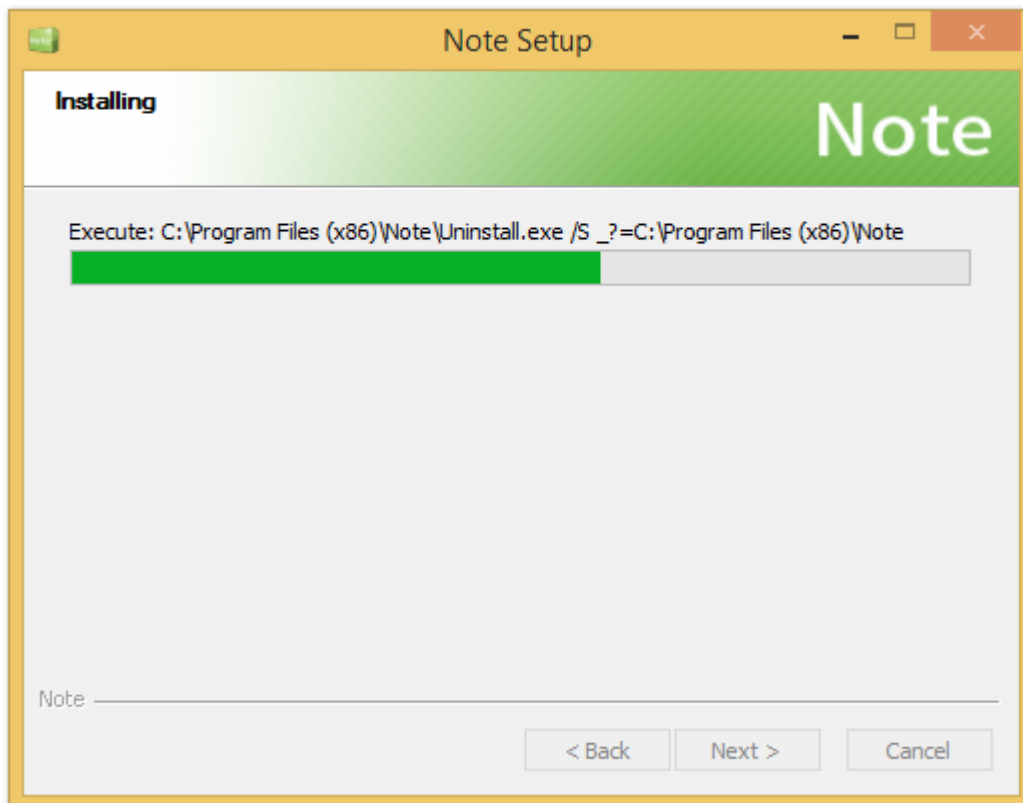

Figure 2-2-3 Installation progress

After the software is installed, the installation completion interface is displayed. See Figure 2-2-4. Click **Finish**. The installation is completed.

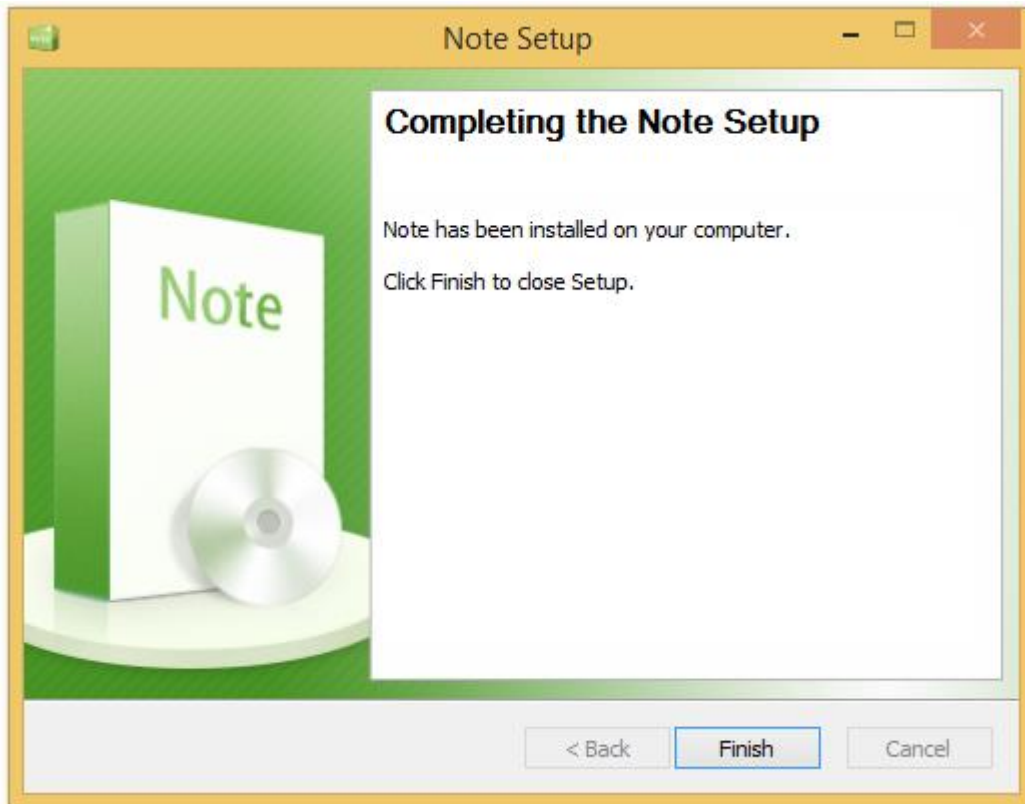



Figure 2-2-4 Installation completion

3 Usage Introduction

After the software is installed, double-click  on the desktop or choose **Start > All Programs > Note** to start the software.

3.1 Basic Functions

The software supports multiple modes: preparation, teaching, desktop and simplified. The basic functions in all modes are the same. The following takes the Presenting mode as an example.

3.1.1 Menu

Click  to display the drop-down menu shown in Figure 3-1-1. The following menu items are available: File (selected by default), Import, Export, Print, Settings, Help, Mode, and Exit.

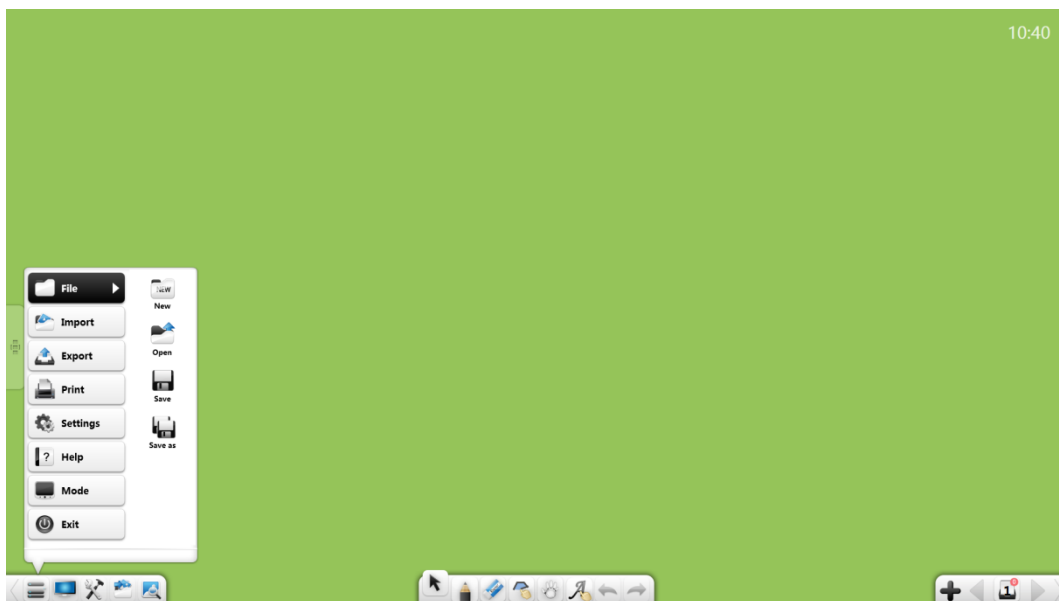



Figure 3-1-1 Start menu

3.1.1.1 File

Click  to display a sub-menu where the items New, Open, Save and Save As are available.

(1) New

Click  to create a blank document, which can contain multiple pages.

(2) Open

Click  to open an *.enb file, which is the default file format of the software.

(3) Save

Click  to save the current document as an *.enb file, which is default format of the software.

(4) Save As

Click  to save the current document as an *.enb file.

3.1.1.2 Import



Click  to display a sub-menu, where you can import files and texts to the current page, handwriting, clipboard and general materials. See Figure 3-1-1-2.



Figure 3-1-1-2 Importing objects

3.1.1.2.1 File

Click  to display the file selection window. You can select an image, video, audio, flash, PDF document, TXT document, Office document, or Note courseware. In preparation mode, you can drag images, videos, audios, flashes, and PDF, TXT, Office, or Note files to the software interface.

(1) File types

- Image files: *.bpm, *.jpg, *.jpeg, *.png, *.ico, *.cur, and *.gif.
- Video files: *.wmv, *.avi, *.mp4, *.rmvb, *.rm, *.mov, *.flv, *.f4v, *.asf, *.mpg, *.3gp, *.mkv, *.mpeg, *.ts, and *.vob.
- Audio files: *.wav, *.wma, *.mp3, and *.mid.
- Flashes: *.swf.
- PDF files: *.pdf.
- TXT files: *.txt.
- Office files: *.ppt, *.pptx.
- Note files: *.enb.

(2) Import PPT files

When you import a PPT file, the original PPT will open a separate window. If the option Enable the PPT presentation tool is selected, you can annotate on PPT page content, erase, magnifying glass, etc. operations. See Figure 3-1-1-2-1-1.

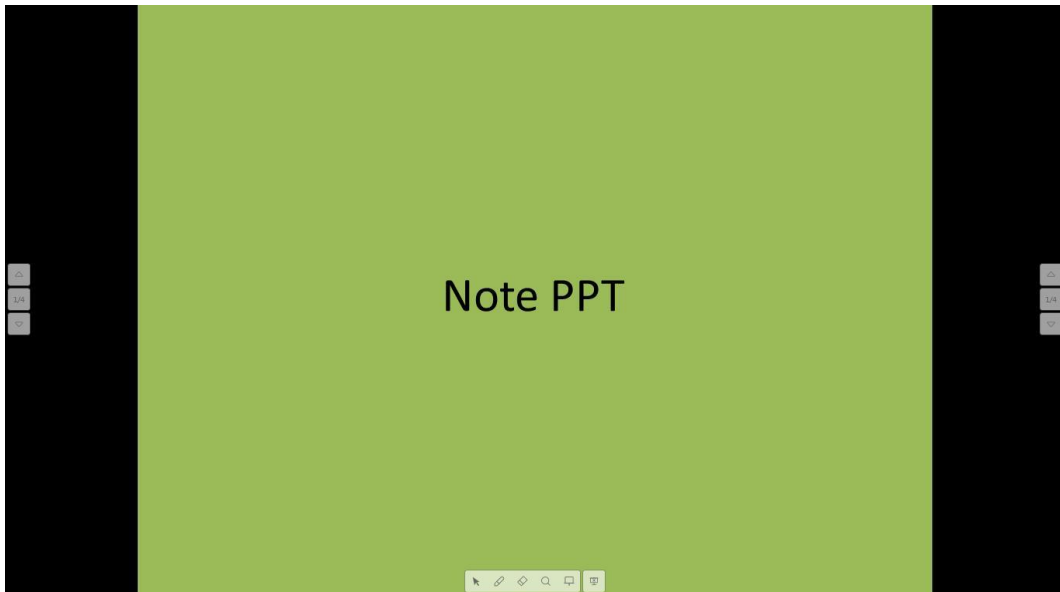





Figure 3-1-1-2-1-1 Play mode

- a) Click the button  to enter play mode;
- b) Click the button  to enable the comment mode
- c) Click the button  to enable the eraser for erasing comments;
- d) Click the button  to enable the spotlight. The spotlight can draw the attention of the audience to a position to be emphasized, see Figure 3-1-1-2-1-2.

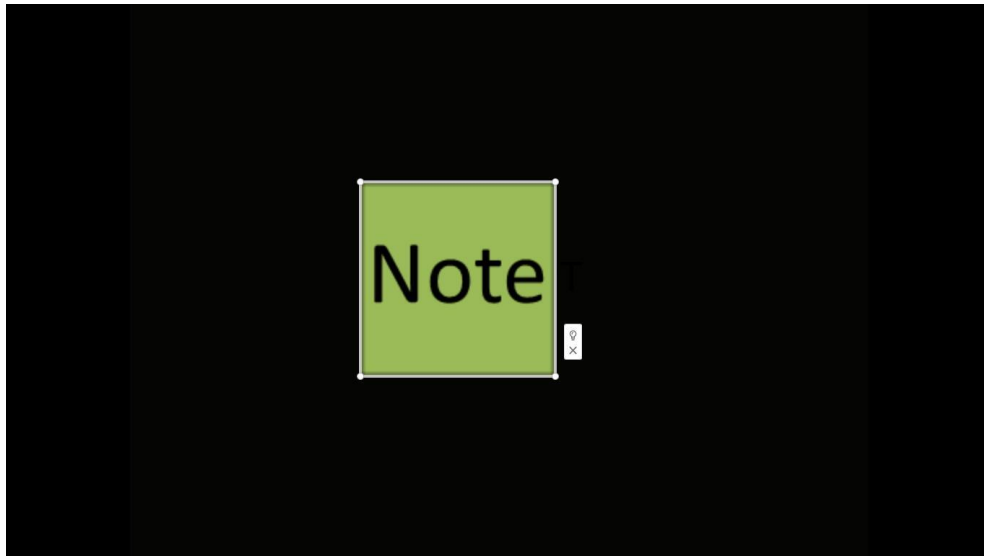











Figure 3-1-1-2-1-2 spotlight

- i. Drag the spotlight to move it, and click the edge of the spotlight to adjust its scope;
 - ii. Click  to make the external display
click  to make the external black
 - iii. Click  to close the spotlight.
- e) Click  to enable the whiteboard
 - f) Click  to end the show;
 - g) Click  to go to the previous page. Click  to go to the next page
 - h) Click  on the both sides to display PPT thumbnail, select the thumbnail to display in the current page.

3.1.1.2.2 Text Editing

Click  to open the text editing box. Enter characters (through the keyboard on the toolbar or the keyboard of the PC). By default, the font is Microsoft Accor Black, the size is 48, and the color is black. See Figure 3-1-1-2-2-1.

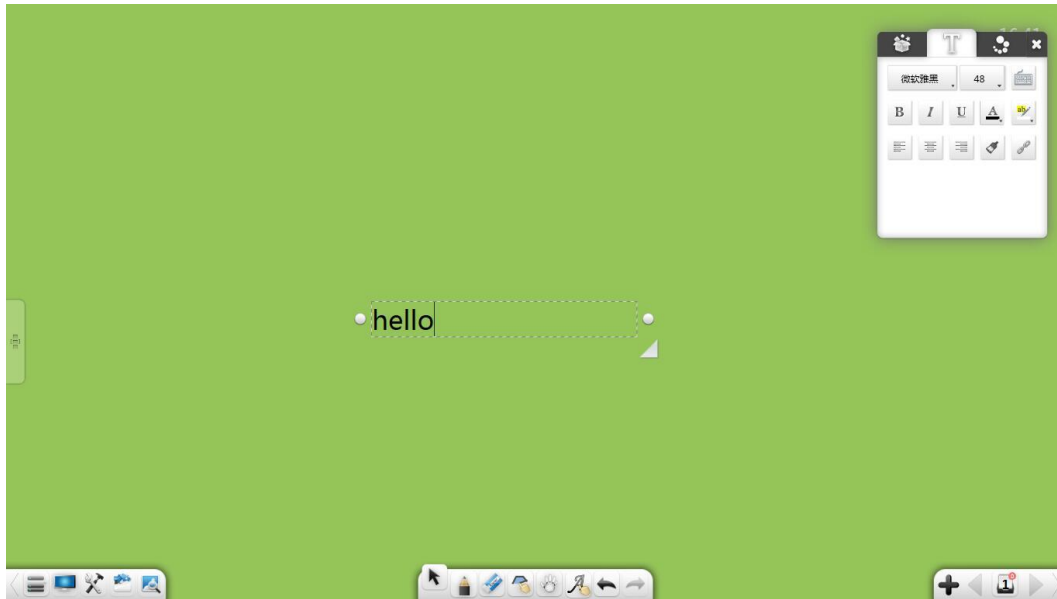

















Figure 3-1-1-2-2-1 Text editing

1. Font: Click the font drop-down list and select a font.
2. Size: Click the size drop-down list and select a size, or manually enter a size. You can also change the size by zooming the object.
3. Keyboard input: Click  to display the keyboard for text input.
4. Boldface: Click  to set the current text in boldface and the button changes to . Click the button again to restore the original thickness.
5. Italic: Click  to set the current text in italic and the button changes to . Click the button again to restore the original text.
6. Underline: Click  to underline the current text and the button changes to . Click the button again to remove the underline.
7. Text color: Click  to display the color palette. You can set the color of the current text.
8. Background color: Click  to display the color palette. You can set the background color of the current text.
9. Align left: Click  to align the text on the right.

10. Align right: Click  to align the text on the left.
11. Align center: Click  to align the text centrally.
12. Format painter: Click  to start the format painter. Select a part of the text, click the format painter, and select another part of the text. Then the second part will be in the same format as the first part.
13. Website link: Select the text and click  to display the hyperlink editing window. You can add a hyperlink to a file, website, text information, page number, audio file, or toolbar. For details, see section 3.1.6.

Note: You need to select a part of text before setting it.

3.1.1.2.3 Handwriting Recognition

Click  to enable the handwriting recognition function and a quill-pen is displayed. After writing on the page, the handwriting is automatically recognized and displayed on the page. See Figure 3-1-1-2-3.

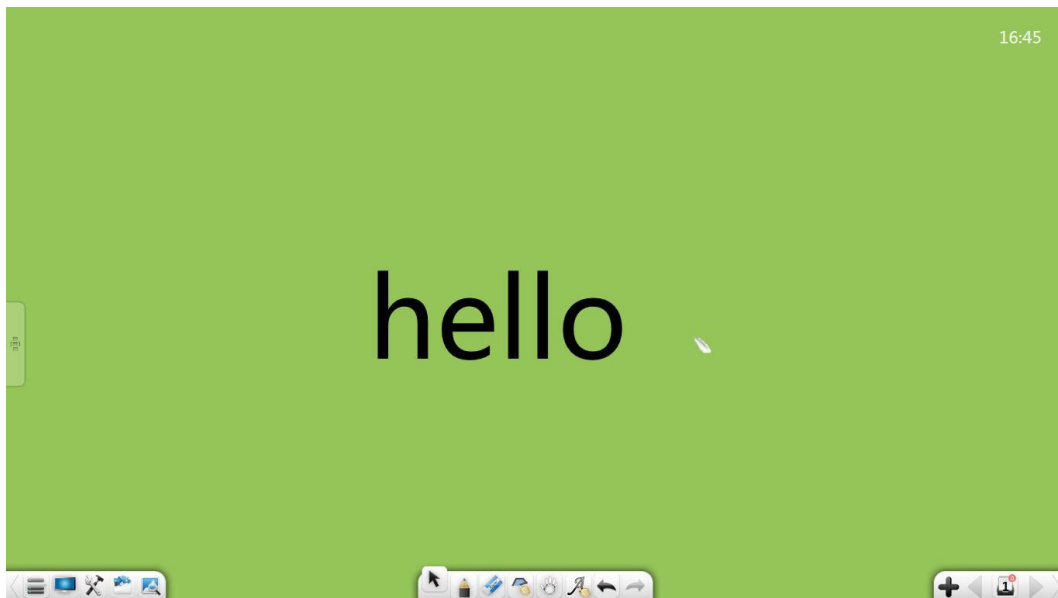





Figure 3-1-1-2-3 Handwriting recognition

3.1.1.2.4 Clipboard

Select an object and click  /  to copy/cut the selected object. During importing, click  to paste the cut or copied object to the current page.

1. You can copy pictures or texts from other places and then paste them on the software interface. The pasted pictures are displayed in 300px. The pasted text is inserted from the upper left corner by default and you can edit the text by using the text editor.
2. A copied/cut object can be pasted at any allowed position like Word and PPT files, or on the page of another opened program.

3.1.1.2.5 General Materials

Click  to access the general material editor. Click a material to insert it into the page. The text editing interface is automatically displayed. You can edit the text and use it as a sub-title. See Figure 3-1-1-2-3.

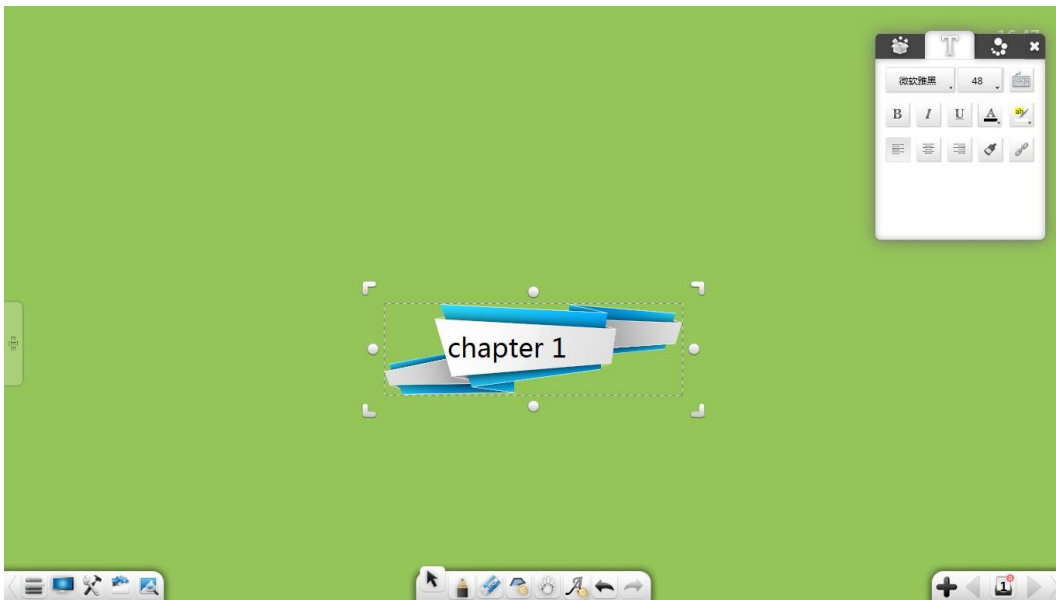



Figure 3-1-1-2-5 General material editing

3.1.1.3 Export

Click  to display a sub-menu. You can export the current file as a picture (*.jpg), Word (*.docx), PPT (*.pptx), or PDF (*.pdf) file.

3.1.1.4 Print

Click  to print the current file. The dialog box shown in Figure 3-1-1-4 is displayed. The interface may vary according to the operating system or printer model.

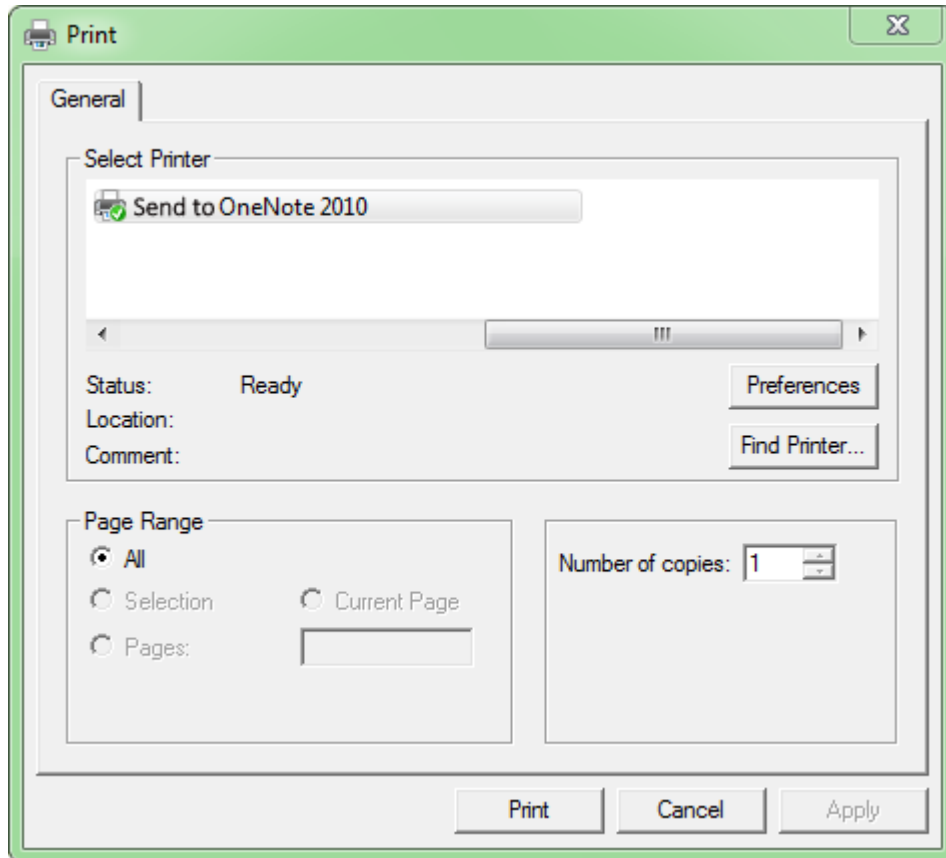



Figure 3-1-1-4 Printing setup

3.1.1.5 Settings

Click  to access the setup window. In the setup window, you can set the language, read aloud speed, default font and size, default drawing colors and default fill colors, page size, recover closed files accidentally, enable automatic updates, enable the PPT presentation tool, and allow erasing while writing. See Figure 3-1-1-5-1. You can set the items as required. The settings take effect immediately.

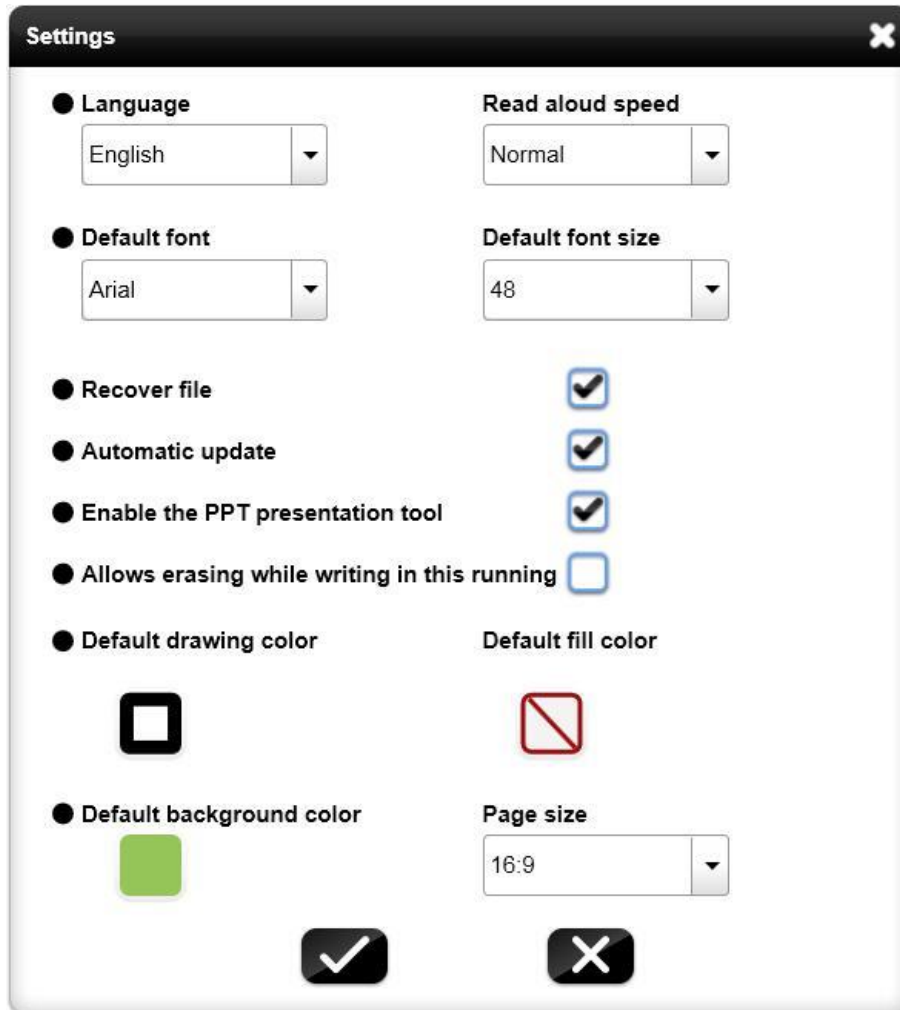

Figure 3-1-1-5-1 Setup interface

1. Language: Click the **Language** drop-down list and change the software language to other language. There are six languages for chosen. They are English, Japanese, Korean, Russian, Simplified Chinese, Traditional Chinese. The language selected during software installation takes effect by default.
2. Read aloud speed: Click the Read aloud speed list and change the reading speed to very slow, slow, normal, fast, or very fast. The default speed is normal. After a speed is selected, the software will read using the selected language at the selected speed. If the selected language is not included in the library, the software will read in English.
3. Default font and size: Click the default font drop-down list and select the default font and size for text editing. The default font is Song and the size is 48.

4. Recover file: If this item is selected, after the software is closed accidentally, you can choose whether to recover the accidentally closed files when you start the software again.
5. Automatic update: If this item is selected, automatic update is enabled for the software. That is, if a later version is available, an update prompt window is displayed automatically when you start the software. You can update the software as required.
6. Enable the PPT presentation tool: If this item is selected, the PPT presentation toolbar appears on the bottom of the page when presenting PPT. You can select, annotate, erase, magnify, whiteboard and other operations.
7. Allows erasing while writing in this running: If this is selected, you can erase the handwriting while writing.



8. Default drawing colors: Click  to display the window for selecting a drawing color. You can set the default color of the handwriting, line, and graph frame. The default color is black. You can select any color on the page or the color picker by the dropper. See Figure 3-1-1-5-2.



Figure 3-1-1-5-2 Selecting the default drawing color

9. Default fill colors: Click  to display the window for selecting a fill color. You can set the default fill color of graph frames. You can select any color on the page or the color palette by the dropper. See Figure 3-1-1-5-3.

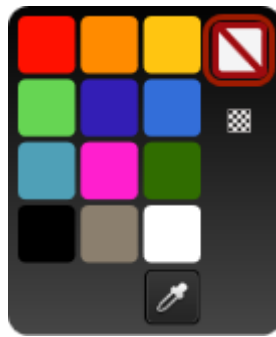

Figure 3-1-1-5-3 selecting the default fill color

10. Default background color: Click the Default background color to display the window for selecting a background color which will be displayed every time when you open the software.

11. Page size: Click the **Page Size** drop-down list and you can select the proportion of 16:9, 16:10 or 4:3. You can choose the page proportion switching mode. Three modes are available: Uniform, Uniform to fill, and Fill. See Figure 3-1-1-5-4.

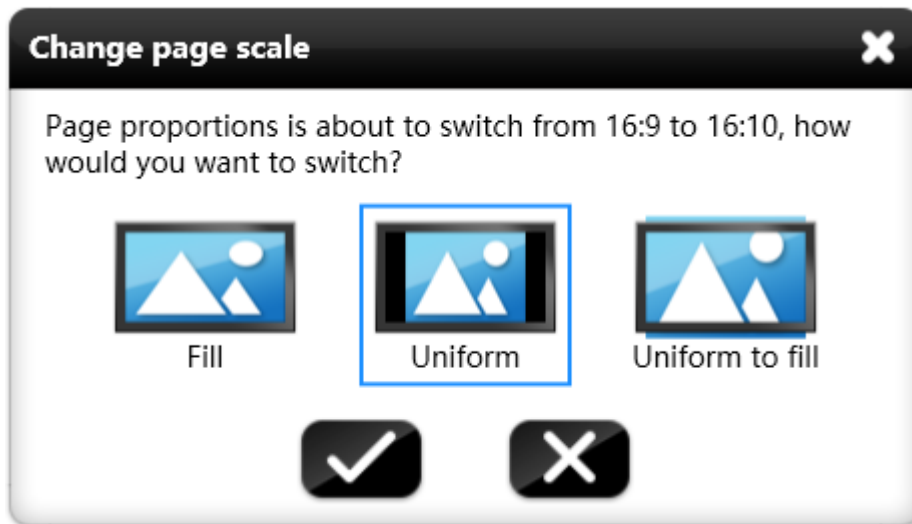



Figure 3-1-1-5-4 Page size switching

3.1.1.6 Help

Click  to display a sub-menu, where the items Usage Description, Activate/Deactivate, Update, About, and Contact Us are available.

3.1.1.6.1 Usage Description

Click  to display the user guide for the software. You can operate the software by referring to the user guide.



3.1.1.6.2 Activate

Click  to activate the software.

Note:

Part of the software functions are unavailable when the software is not activated.

(1) Not activated

If the software has never been activated, an **activate input** box will pop up. In the displayed text box, enter the serial number and click . See Figure 3-1-1-6-2-1. Click  to cancel the activation operation and return to the software interface. (Note: The software needs to be activated online.)

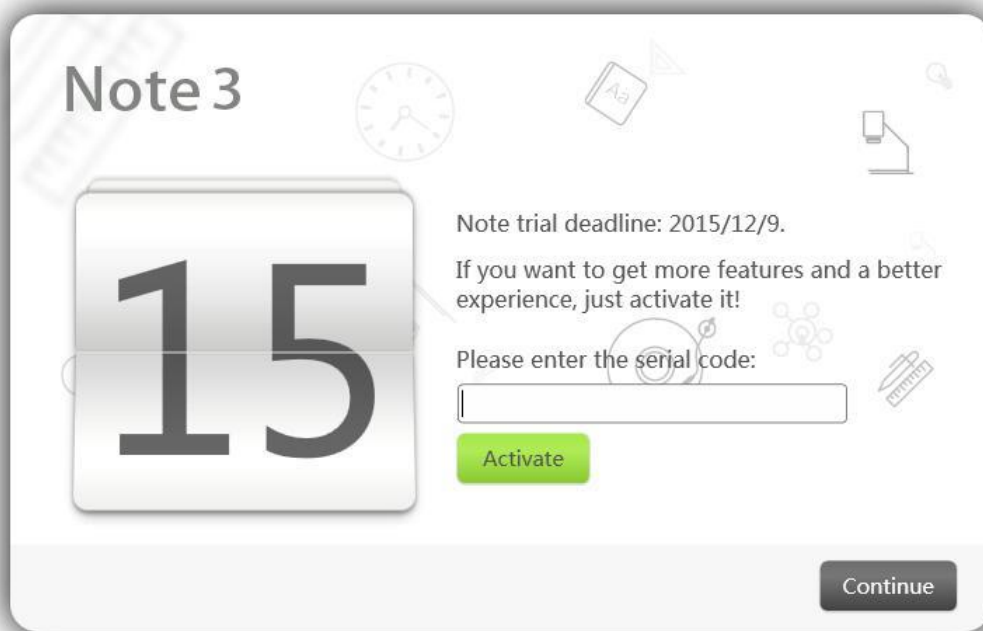

Figure 3-1-1-6-2-1 Entering the serial number

(2) Activated

If the software has been activated, the prompt shown in Figure 3-1-1-6-2-2 is displayed.

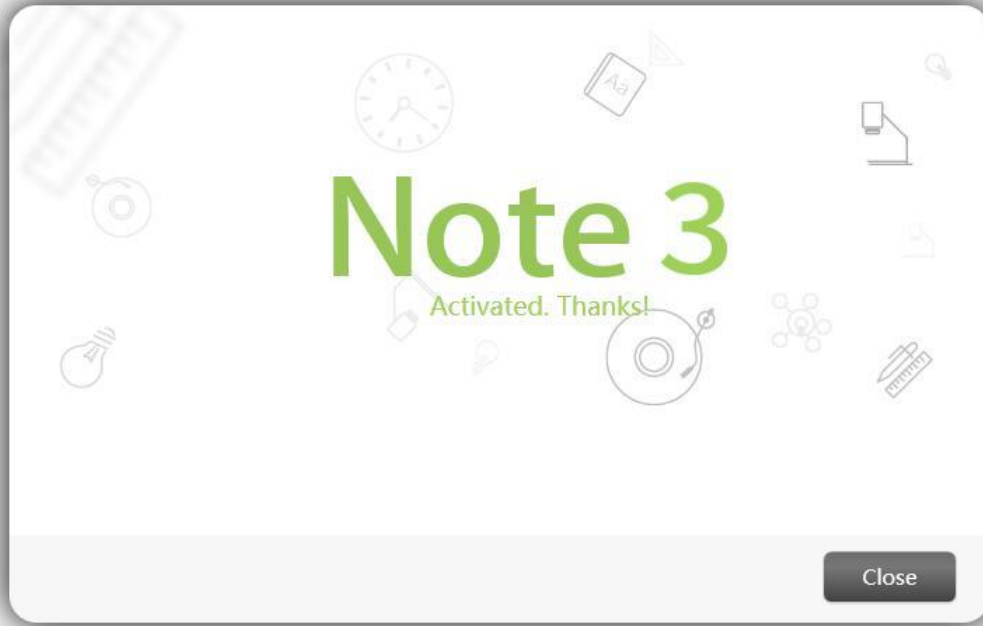

Figure 3-1-1-6-2-2 Software activation prompt

3.1.1.6.3 Update

(1) The software is not of the latest version

If the software is not of the latest version and the PC is connected to the network, the online upgrade prompt window is automatically displayed when you start the software. See Figure 3-1-1-6-3-1.

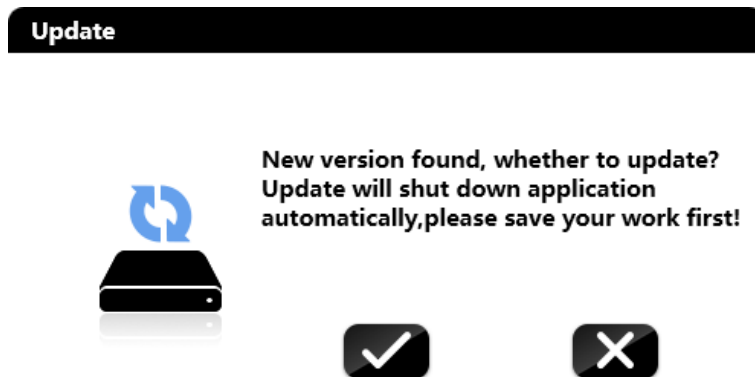





Figure 3-1-1-6-3-1 Update detection interface

Click to upgrade the software online. The software is closed and automatically upgraded. The software upgrade interface is displayed. See Figure

3-1-1-6-3-2. Click  to not upgrade the software. If the file contents need to be saved, click  to cancel the upgrade and save the file. During the upgrade, click  to hide the upgrade interface. The upgrade will then be performed at the background.

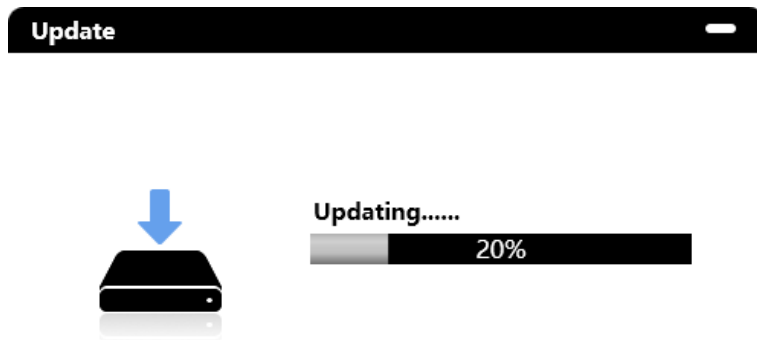

Figure 3-1-1-6-3-2 Upgrade in progress

After the software is upgraded, the interface shown in Figure 3-1-1-6-3-3 is displayed, with the function updates displayed.

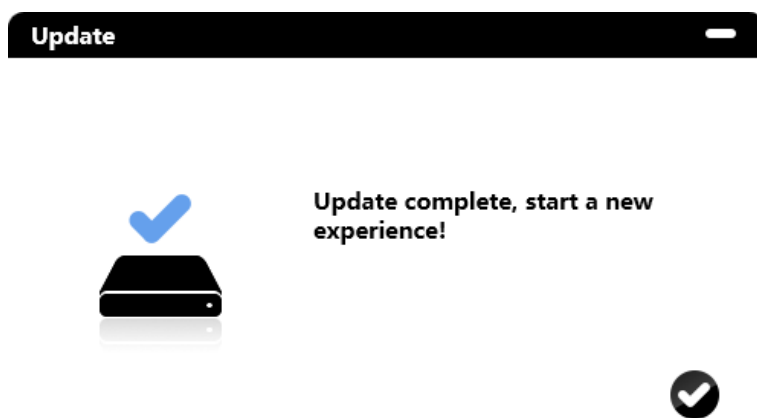



Figure 3-1-1-6-3-3 Update completion

(2) The software is of the latest version

If the software is of the latest version, the online upgrade prompt window will not be displayed. Click  and the online upgrade prompt window is displayed. See Figure 3-1-1-6-3-4.

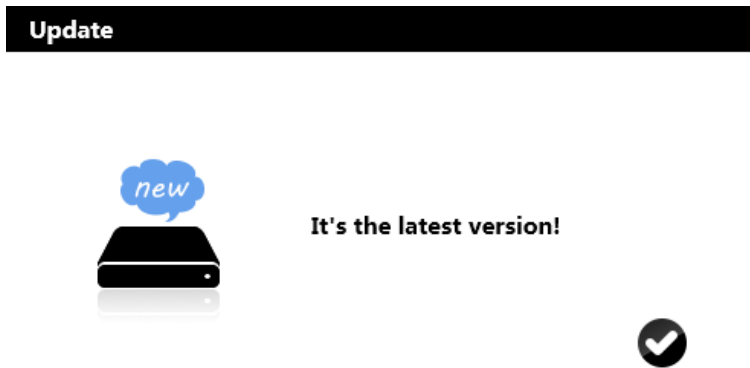



Figure 3-1-1-6-3-4 Upgrade prompt window

(3) There is no network connection

If the PC is not connected to the network, online upgrades cannot be performed. In this case, you need to manually remove the original software and install the new one. Click  and a prompt indicating no network connection is displayed. See Figure 3-1-1-6-3-5.

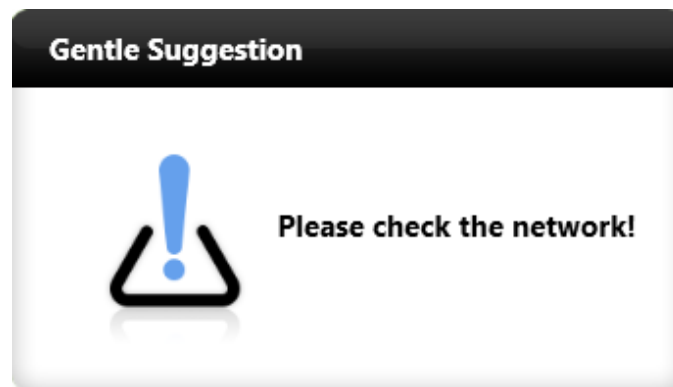



Figure 3-1-1-6-3-5 No network connection

3.1.1.6.4 About

Click . The interface shown in Figure 3-1-1-6-4 is displayed, with the software name, version, and official website displayed.

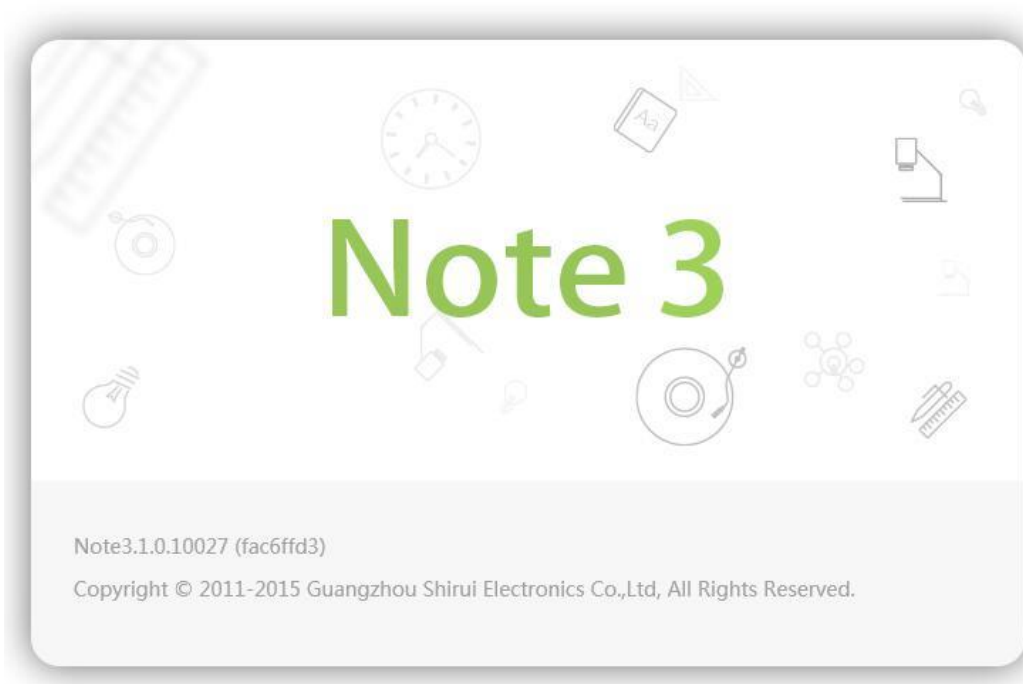

Figure 3-1-1-6-4 About information

3.1.1.6.5 Contact Us

Click  . The interface shown Figure 3-1-1-6-5 in is displayed. Click



 , enter contents, and click  to send an email to software R&D engineers.



Figure 3-1-1-6-5 Contact Us interface

3.1.1.7 Mode

Click  to display a sub-menu, where you can change the display mode to presenting, preparation, desktop. For details, see section 3.2.

3.1.1.8 Exit

Click  to exit the software. If a file is not saved when you exit the software, a prompt is displayed asking whether to save the file. See Figure 3-1-1-8. Click **Yes** to save the file, **No** to exit The software, or **Cancel** to cancel the exit operation.

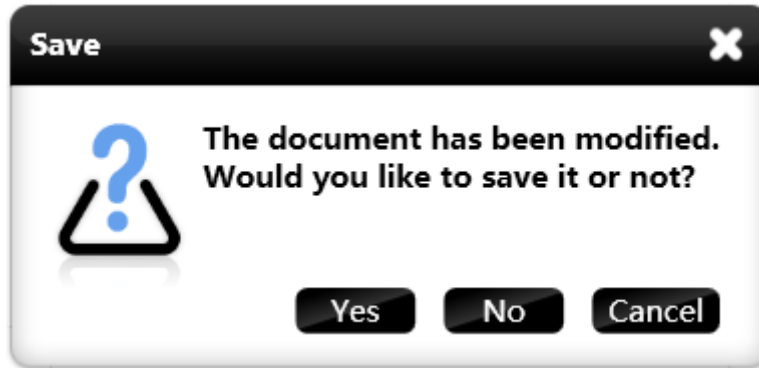



Figure 3-1-1-8 File saving prompt

3.1.2 Desktop

Click  to switch to desktop mode. For details, see section 3.2.3.

3.1.3 Treasure Chest

Click  to display the treasure chest page, where the Subject, Subject Tool, Small Tool, and More items are displayed. In Presenting mode, the Small Tool tab is displayed by default. See Figure 3-1-3. After the subject scenario is changed, the Subject Tool tab corresponding to the current subject scenario is displayed by default.

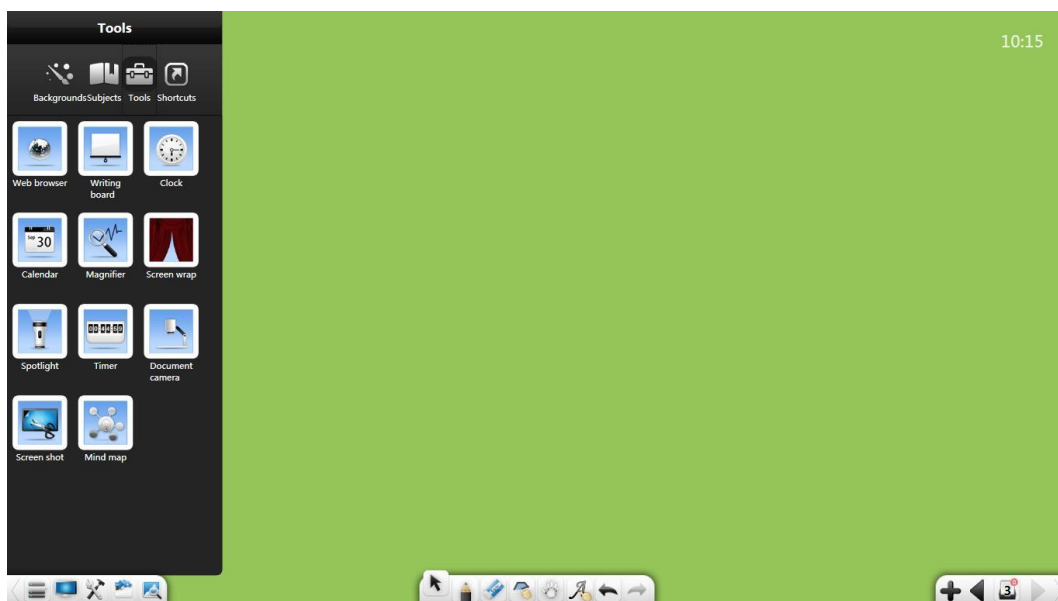

Figure 3-1-3 Treasure chest interface

3.1.3.1 Backgrounds



Click  and select the solid color background, subject background, miscellaneous background, and custom as required. See Figure 3-1-3-1-1.



Figure 3-1-3-1-1 Subject interface

(1) Solid Color

Click the **Solid Color** item and the color picker is displayed. You can select any color. You can click  and select a color on the color picker or at any position on the interface and apply it as the background color of the interface.

(2) Subjects background

Click the **Subjects** item. On the subject background setup interface, you can select lattice, line, stave or chessboard as the subjects background. See Figure 3-1-3-1-2.

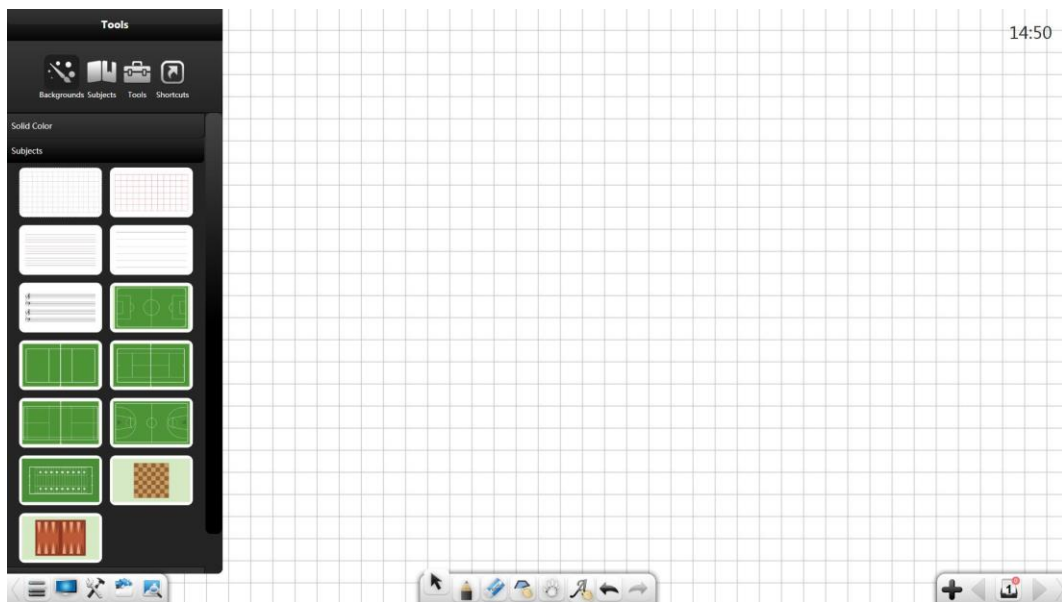

Figure 3-1-3-1-2 Subjects background

(3) Miscellaneous

Click the **Miscellaneous** item. On the Miscellaneous setup interface, you can select the ink painting, geographic, or concise style. See Figure 3-1-3-1-3.



Figure 3-1-3-1-3 Miscellaneous background

(4) Custom

Click the **Custom** item. On the custom setup interface, you can select local image from your computer as the background. See Figure 3-1-3-1-4.

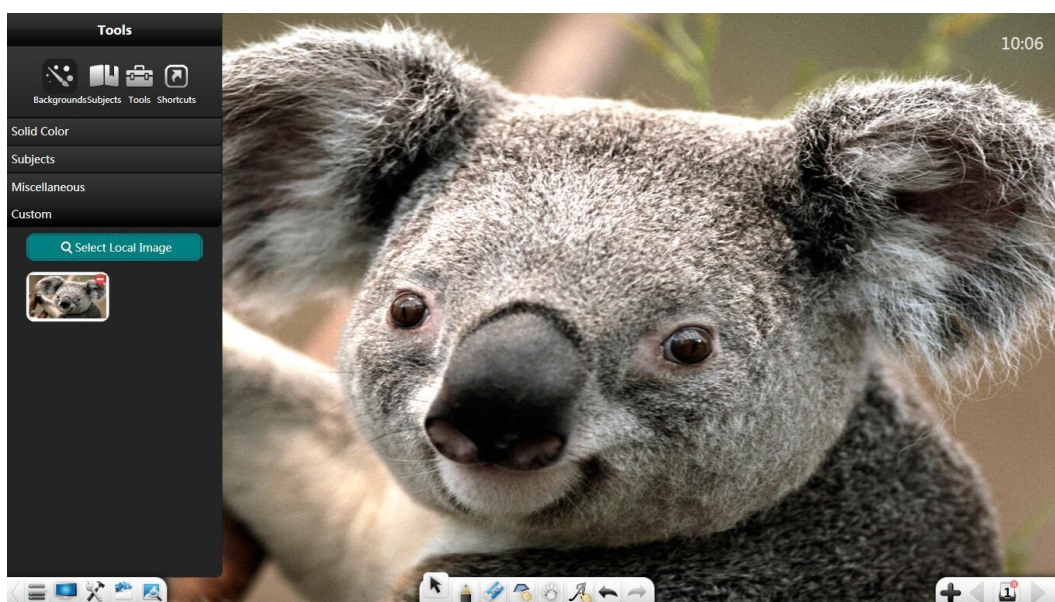

Figure 3-1-3-1-4 Custom background

3.1.3.2 Subjects



Click  and select corresponding tools to assist teaching based on the current teaching scenario, including chemistry, physics, and math. See Figure 3-1-3-2-1. For details about the tools for chemistry, physics, and math, see the descriptions of the corresponding subject mode.



Figure 3-1-3-2-1 Subjects Tool interface

3.1.3.3 Tools

Click  to display the **Tools** interface. See Figure 3-1-3-3.

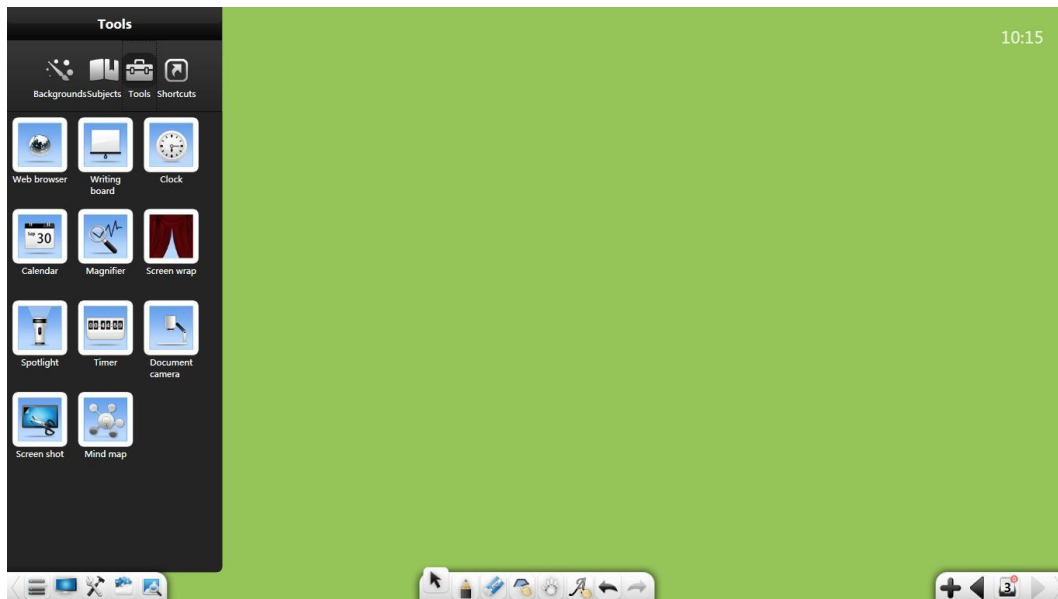

Figure 3-1-3-3 Tools interface

3.1.3.3.1 Web browser





Click  to open the Web browser. See Figure 3-1-3-3-1. Then you can search and browse resources.



Figure 3-1-3-3-1 Web Browser

1. Back: Click  to go back to the previous page.
2. Forward: Click  to go to the next page.
3. Refresh: Click  to refresh the current page.
4. Favorites folder: Click  to display the favorites folder. See Figure 3-1-3-3-1-2. You can modify the favorites folder as required.

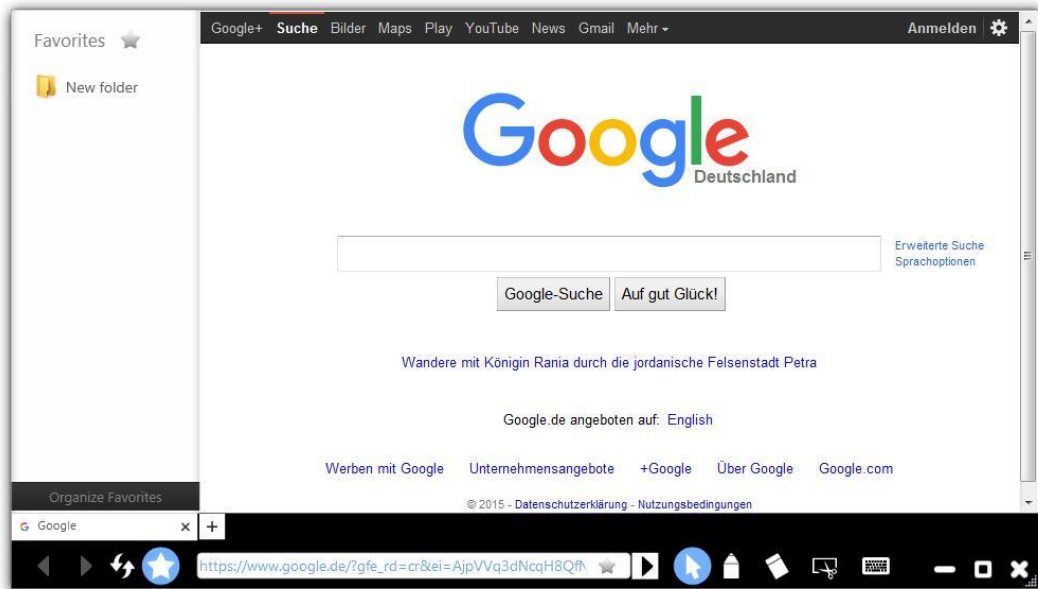



Figure 3-1-3-3-1-2 Favorites folder

5. Favorite: Click  on the right of the address bar to add the current website to the favorites folder. See Figure 3-1-3-3-1-3.

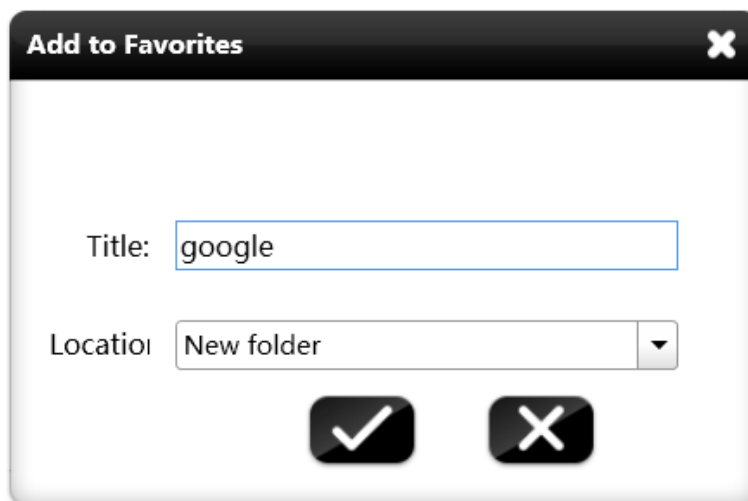

Figure 3-1-3-3-1-3 Adding a website to the favorites folder









6. Jump: Click  to jump to the current website displayed on the address bar.
 7. Return: Click  to exit the comment/erase mode and return to the webpage.
 8. Comment/erase: Click  to add a comment on the current page and  to erase the added comment.
 9. Screenshot: Click  to take a rectangular screenshot of any contents on the screen. The screenshot will be automatically inserted into the software interface. For details, see section 3.1.3.3.10.
 10. Screen keyboard: Click  to display the screen keyboard. You can enter search keywords quickly by using this keyboard.
 11. Minimize: Click  to minimize the browser window. Then the thumbnail icon of the browser is displayed on the taskbar of the main interface.
- Click  to display the thumbnail and click the thumbnail to go back to the webpage. See Figure 3-1-3-3-1-4.



Figure 3-1-3-3-1-4 Web Browser thumbnail

12. Maximize/restore: Click  to maximize the browser window or  to restore the window size.

13. Close: Click  to close the Web browser.

3.1.3.3.2 Writing board

Click  to open the Writing board. See Figure 3-1-3-3-2.

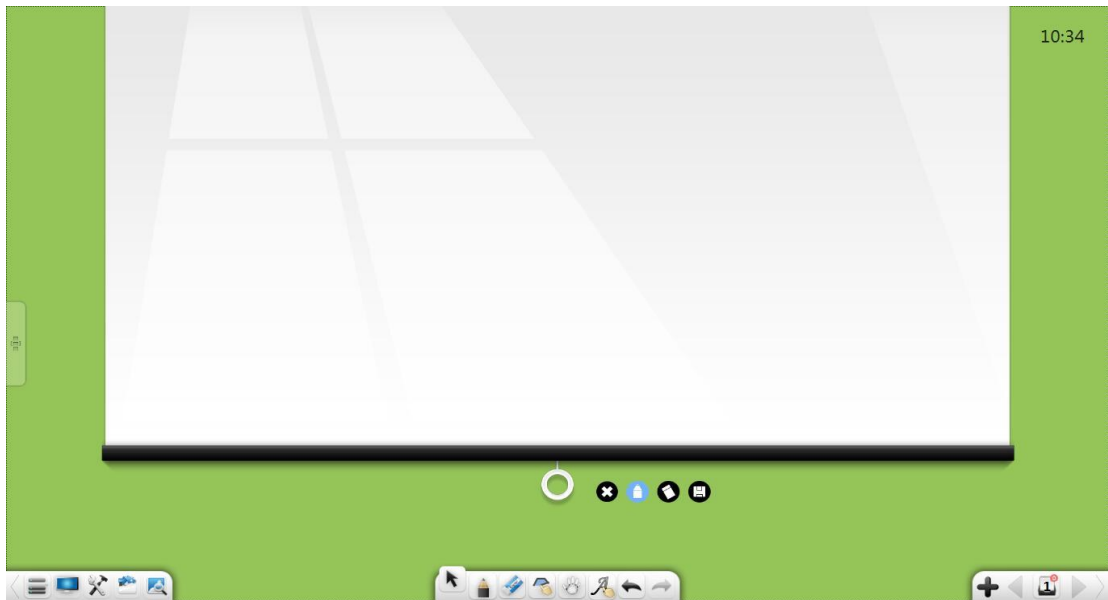





Figure 3-1-3-3-2 Writing board

1. Expand/collapse the Writing board: Click the white ring to drag the Writing board upwards or downwards.

2. Write: Click  and write on the Writing board. By default, the handwriting is thin in black.

3. Eraser: Click  to erase the handwriting.

4. Export: Click  to export the handwriting on the Writing board as a .png picture.

5. Close: Click  to close the Writing board.

3.1.3.3 Clock



Click  to access the clock interface. See Figure 3-1-3-3-3.



Figure 3-1-3-3-3 Clock

3.1.3.4 Calendar

Click  to access the calendar. By default, the current year, month, day, and week are displayed. See Figure 3-1-3-3-4-1.

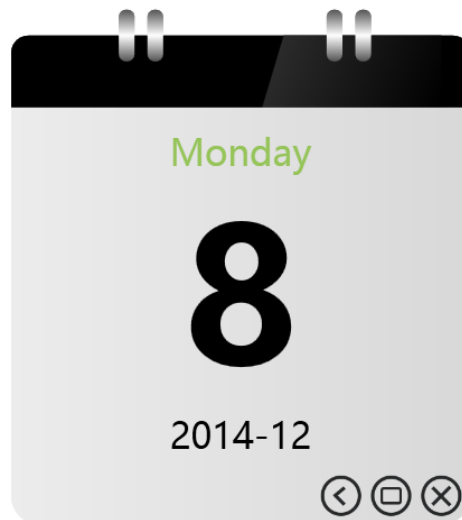



Figure 3-1-3-3-4-1 Default calendar

(1) Calendar

Click  to display the calendar view. See Figure 3-1-3-3-4-2. Click the forward and backward buttons to switch between months, and click the displayed date to change the year and month.

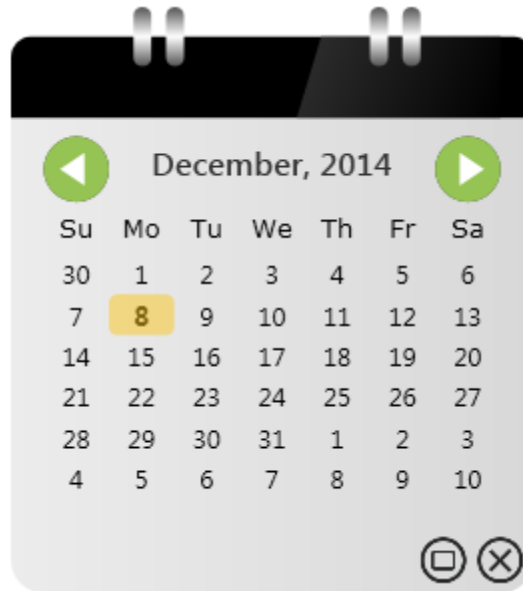





Figure 3-1-3-3-4-2 Calendar view

(2) Zoom

Click  to zoom in the calendar view and  to restore the original size.

(3) Close

Click  to close the calendar view.

3.1.3.3.5 Magnifier







Click  to start the magnifier. See Figure 3-1-3-3-5. Click a point in the magnifier and drag it to move the magnifier to any area to be magnified. Drag the edges of the area to adjust the area size. Click  and drag to set the magnification.



Figure 3-1-3-3-5 Magnifier

3.1.3.3.6 Screen wrap

Click  to start the Screen wrap tool. See Figure 3-1-3-3-6. The Screen wrap can be used to shut out contents not to be shown. You can adjust the position to be shut out by dragging the Screen wrap. After the Screen wrap moves or the rectangle is specified, the icon  is displayed. Click this icon to reset the Screen wrap. Click  to customize the Screen wrap and apply the inserted picture. If no picture is inserted, the Screen wrap takes effect. Click  and select a local picture as the Screen wrap.

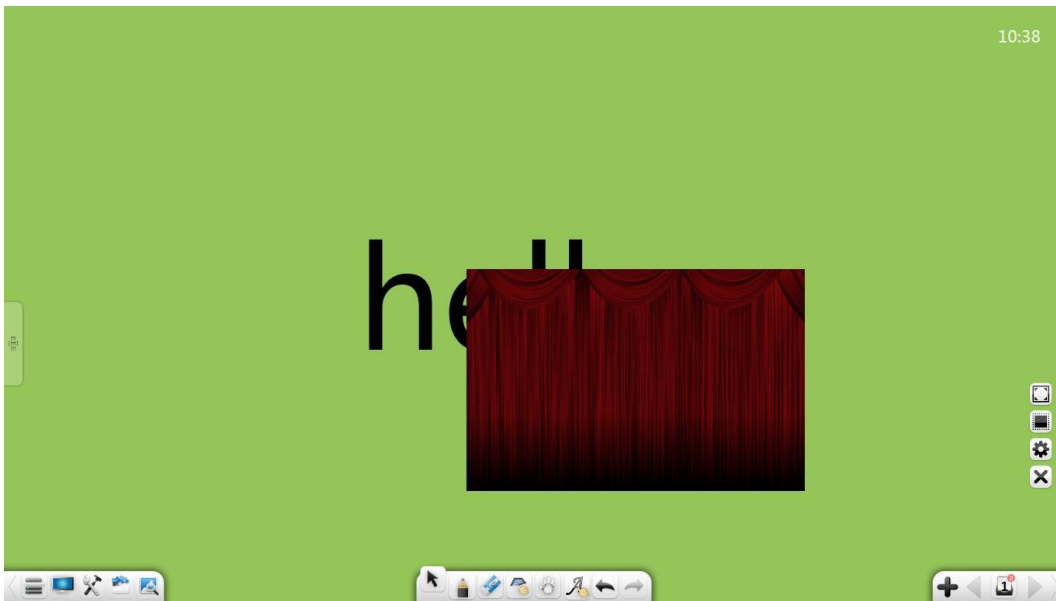



Figure 3-1-3-3-6 Screen wrap interface

3.1.3.3.7 Spotlight

Click  to start the spotlight. See Figure 3-1-3-3-7. The spotlight can draw the attention of the audience to a position to be emphasized.

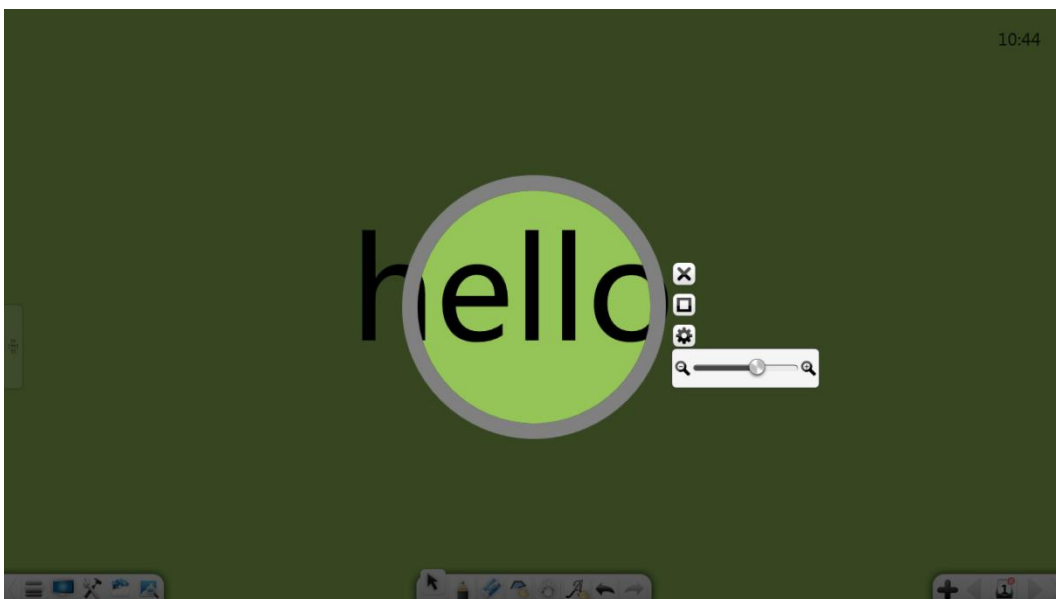





Figure 3-1-3-3-7 Spotlight interface

1. Drag the spotlight to move it.
2. Click the edge of the spotlight to adjust its scope.

3. The spotlight area is round by default. Click  to change the spotlight area to rectangular or  to restore the spotlight area to round.
4. Click  to set the transparency of the part shut out by the spotlight.

3.1.3.3.8 Timer

Click  to start the timer. See Figure 3-1-3-3-8.

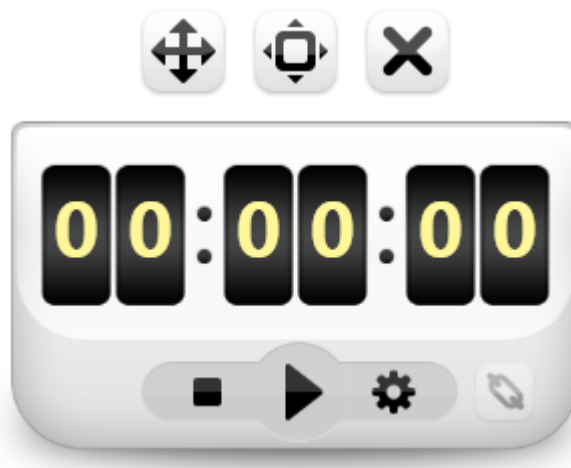







Figure 3-1-3-3-8 Timer

1. **Timing:** Click  to start timing.
2. **Reset:** Click  to reset the timer to 00:00:00.
3. **Setup:** Click  to set the count-down time and  to set the event to be triggered after the timer expires, including files, websites, texts, whiteboard page, audio, and tools.

3.1.3.3.9 Document camera

Click  to start the Document camera. You can present the current material object, lock the screen, revolve leftwards or rightwards by 90 degrees, display full screen, restore the original size, zoom the object, lock the screen, move the camera, add and erase comments, take pictures, minimize the screen, or close the screen. See Figure 3-1-3-3-10.

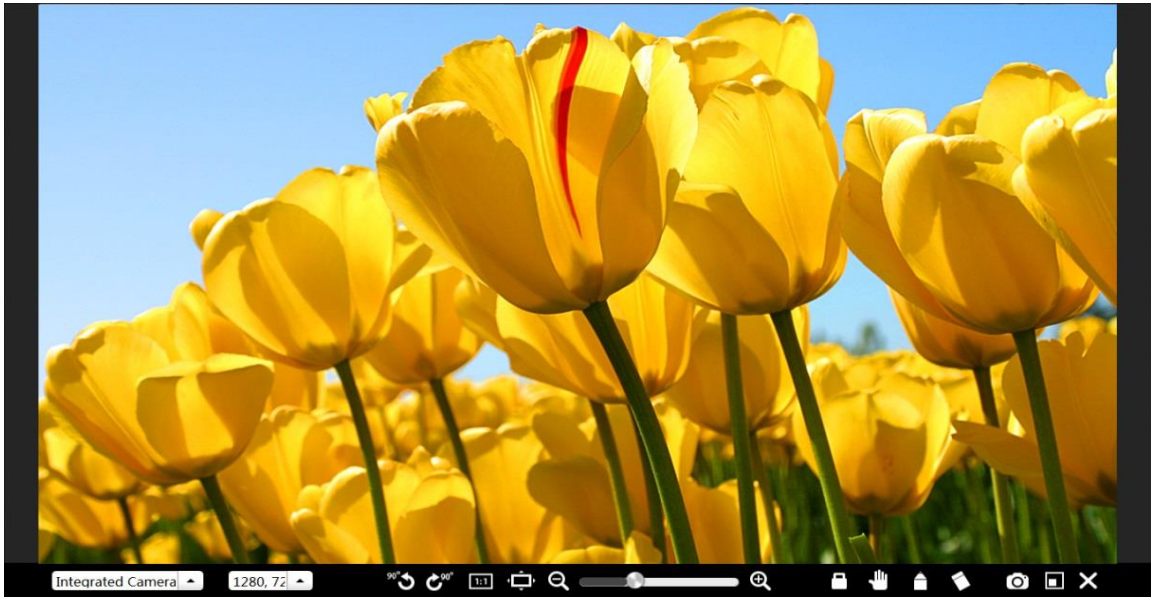













Figure 3-1-3-3-10 Document camera

1. Click  to revolve the object anti-clockwise by 90 degrees.
2. Click  to revolve the object clockwise by 90 degrees.
3. Click  to present the object based on its actual scale.
4. Click  to present the object in full screen.
5. Click  to zoom in or out the object.
6. Click  to lock the object presented on the Document camera. When you try to move the object, it will not move. You can click the button again to unlock the object.
7. Click  to enable picture operating mode. You can move the presented object.
8. Click  to enable comment mode. You can add comments on the presented object. Click the button again to change the color of the pen to red, orange, green, blue, or black.
9. Click  to take a picture of the presented object and show the picture on the software interface. The picture is automatically uploaded to the software interface after being taken. To use the Document camera again, start it again.

10. Click  to return to Presenting mode.
11. Click  to close the Document camera.

3.1.3.3.10 Screen shot

Click  to start the screenshot tool. See Figure 3-1-3-3-10-1.



Figure 3-1-3-3-10-1 Screenshot tool

1. Click  to take a screenshot of the entire screen. After you click this button, a screenshot of the entire screen is automatically taken and inserted into the software interface as a picture. See Figure 3-1-3-3-10-2.



Figure 3-1-3-3-10-2 Screenshot inserted into the software interface

2. Click  and drag a rectangle on the interface. See Figure 3-1-3-3-10-3.
You can adjust the position and size of the rectangle.



Figure 3-1-3-3-10-3 Rectangular screenshot



Click  to insert the screenshot into the software page. See Figure 3-1-3-3-10-4. Click  to cancel the operation of taking a screenshot.



Figure 3-1-3-3-10-4 Rectangular screenshot inserted into the software interface

3. Click  to take a screenshot at will. Select an area for taking a screenshot. See Figure 3-1-3-3-10-5. The screenshot is then automatically inserted into the software interface.

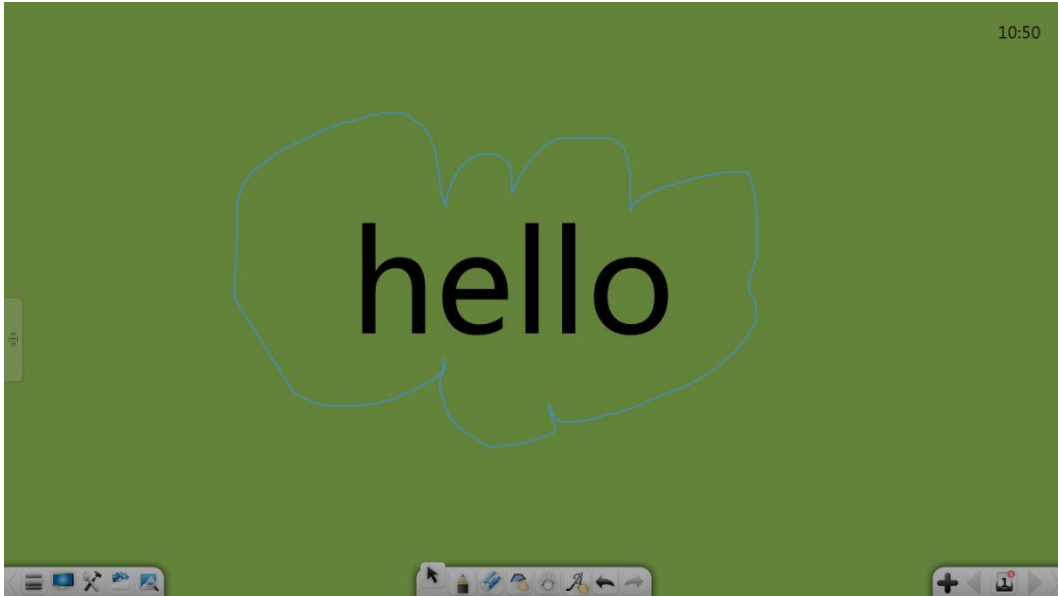





Figure 3-1-3-3-10-5 Taking a screenshot at will

4. Click  and drag to adjust the position of the screenshot tool.
5. Click  to close the screenshot tool.

3.1.3.3.11 Mind map

Click  to display a mind map. See Figure 3-1-3-3-11-1.

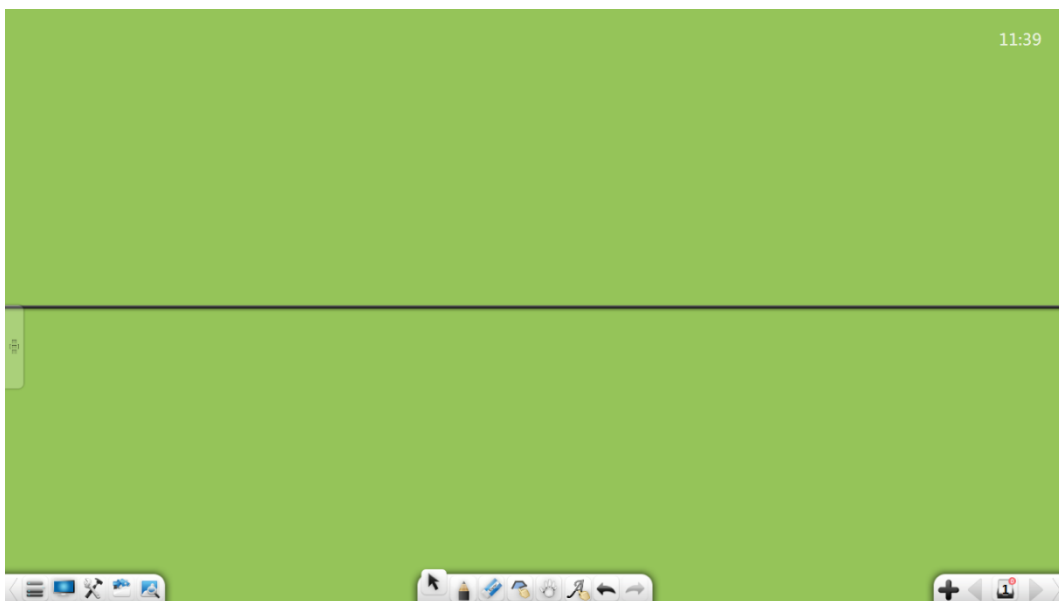

Figure 3-1-3-3-11-1 Mind map

(1) Editing

When the software is under the preparation mode, you can edit the mind map. See Figure 3-1-3-3-11-2.

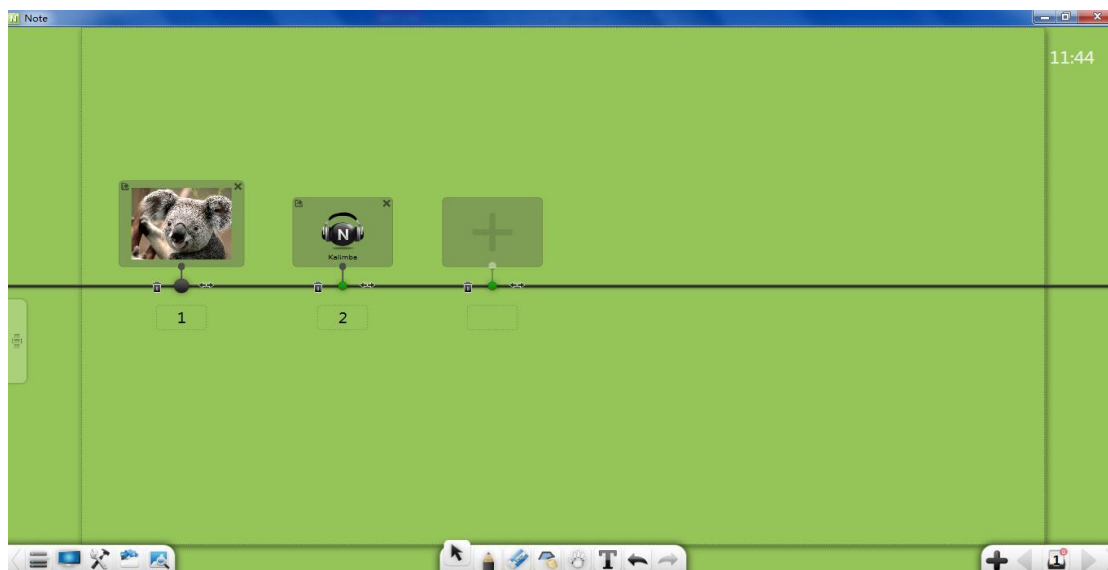













Figure 3-1-3-3-11-2 Editing the guide axis

1. Add nodes: The button  appears while moving the mouse to the line of the mind map, you can click the button to add nodes. Click  to add a big node. Click  to add a small node.
2. Add materials: You can add materials in two ways:
 - a) Select a material (including texts, pictures, audios, and videos) and drag it to the specified node box. The selected material will then be added to this node.
 - b) Click  in a node box to display the box for selecting local resource materials. Select a material (text, picture, audio, or video) and click Open to add the material to this node.
3. Export materials: Click  in the upper left corner of the node box to export the materials of this node to the page.
4. Delete materials: Click  in the upper right corner of the node box to delete the materials of this node.

5. Delete nodes: Click  on the left of a node to delete the node.
6. Move nodes: Click and drag  or  to move the corresponding node leftwards or rightwards.
7. Move nodes partially: Click and drag  on the right of a node to move this node and all nodes on its right side.
8. Move nodes wholly: Click and drag the guide axis to move all nodes on the axis leftwards or rightwards.
9. Name nodes: Enter characters in the text box below a node to name this node.
10. Preview: Click the material of a node to display the preview interface. The hyperlink function in editing mode is different from that in play mode. Other functions are the same. For details, see the description below.
 - a) Hyperlink: If you preview materials in editing mode, click  to set a hyperlink for the node. For details about hyperlink editing, see section 3.1.6.1.

(2) Play

When the Software is under the Presenting mode, you can play the mind map. See Figure 3-1-3-3-11-3.

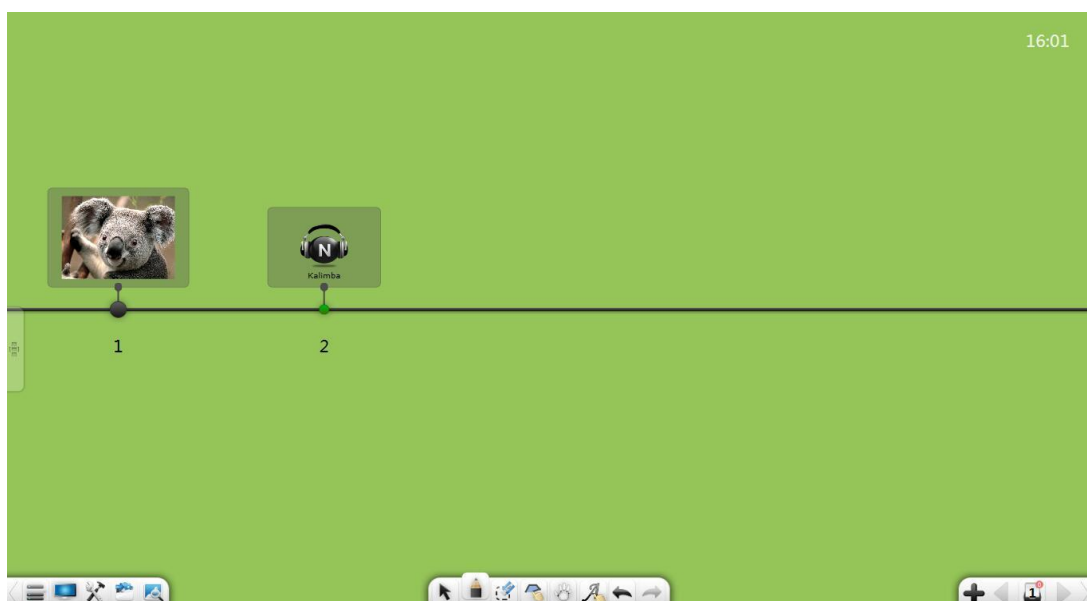

Figure 3-1-3-3-11-3 Editing the mind map

1. Move the guide axis: Click and drag the guide axis to move all nodes on the axis.
2. Play: Click a picture or text material. The material window is displayed. See Figure 3-1-3-3-11-4.

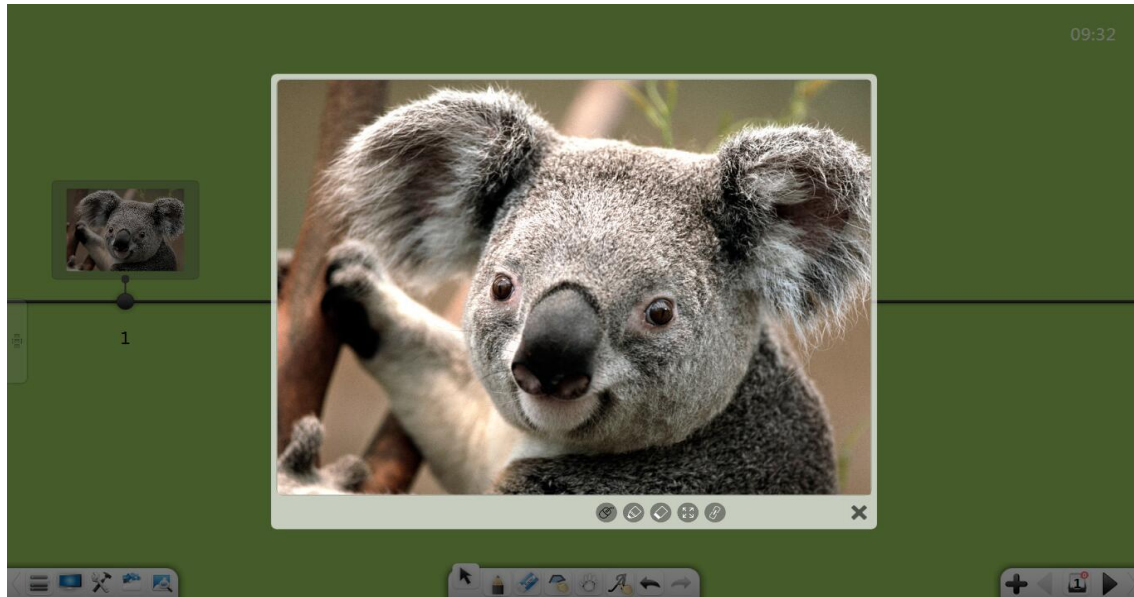









Figure 3-1-3-3-11-4 Picture/text play

- a) Mouse: Click  to exit the writing mode.
- b) Comment: Click  to add a comment to the material.
- c) Erase: Click  to erase the comment added to the material.
- d) Maximize: Click  to maximize the material.
- e) Hyperlink: Click  to access the contents to which the hyperlink links.
- f) Close: Click  in the lower right corner to close the current play window.
- g) Zoom: On a touchscreen device, you can tap on two points concurrently to zoom in or out the material.

3.1.3.4 Shortcuts

Click  to access the more resources interface.

1. Add shortcuts: Click  to add a shortcut to a video, audio, or file.
2. Open shortcuts: Click a file shortcut to quickly open the file.
3. Edit shortcuts: Click **Edit** to quickly delete a shortcut.

3.1.4 Resource Library

Click  to access the resource library shown in Figure 3-1-4-1. The My Computer tab is displayed by default.

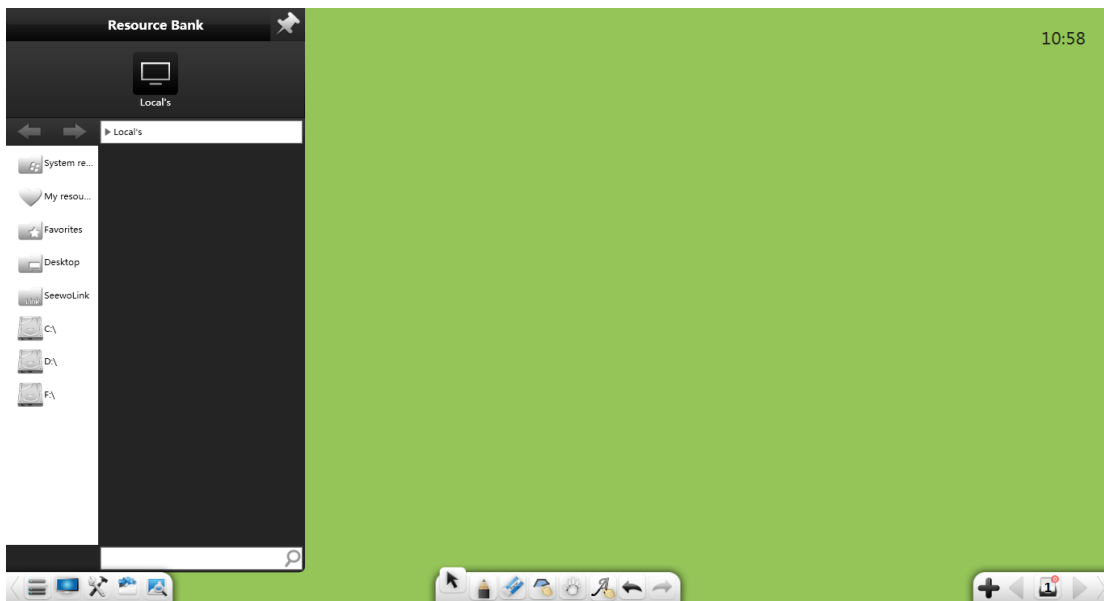











Figure 3-1-4-1 Resource library interface

1. Lock: Click  in the upper right corner of the resource library window to lock the window.
2. Search: In the lower part of the resource library window, enter a resource name in the text box and click  to perform a quick search for resources in the current folder.

Click  to browse system resources, personal resources, favorites, desktop resources, and resources on all disk of the computer. You can browse and locate the target folder, select a resource (handwriting, picture, flash, audio, or video), and double-click or drag the resource to the software interface.

1. Click  or  on the address bar to navigate to the previous or next level of the directory.
2. Click  to select all resources under the current directory.
3. In My Resources, click  to delete the selected resource.
4. On any drive of the computer, click  on the address bar to add the navigation path of the current folder to the favorites folder. Then you can browse files in the favorites folder.

(1) System Resources

Click  to browse and navigate to the target folder, select a resource for demonstration, and double-click or drag the resource to the software interface. See Figure 3-1-4-2.

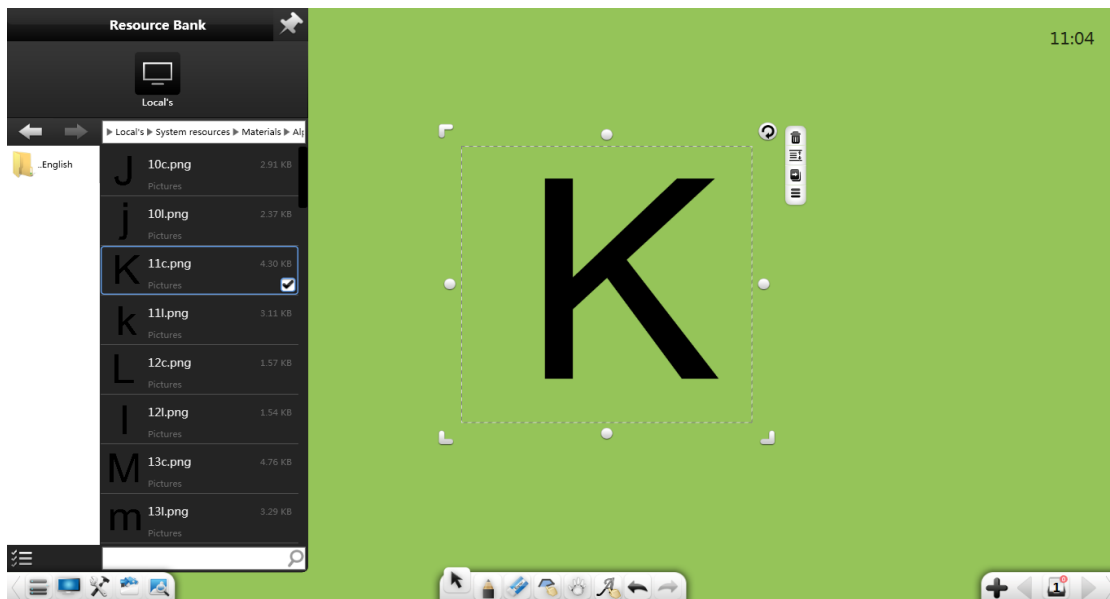



Figure 3-1-4-2 System Resources interface

(2) My Resources

Click  to browse the resources added to the resource library. If you have added resources like handwritings, texts, pictures, flashes, audios, and videos to specific folders in the resource library, you can revoke the resources in **My Resources** at any time. See Figure 3-1-4-3.

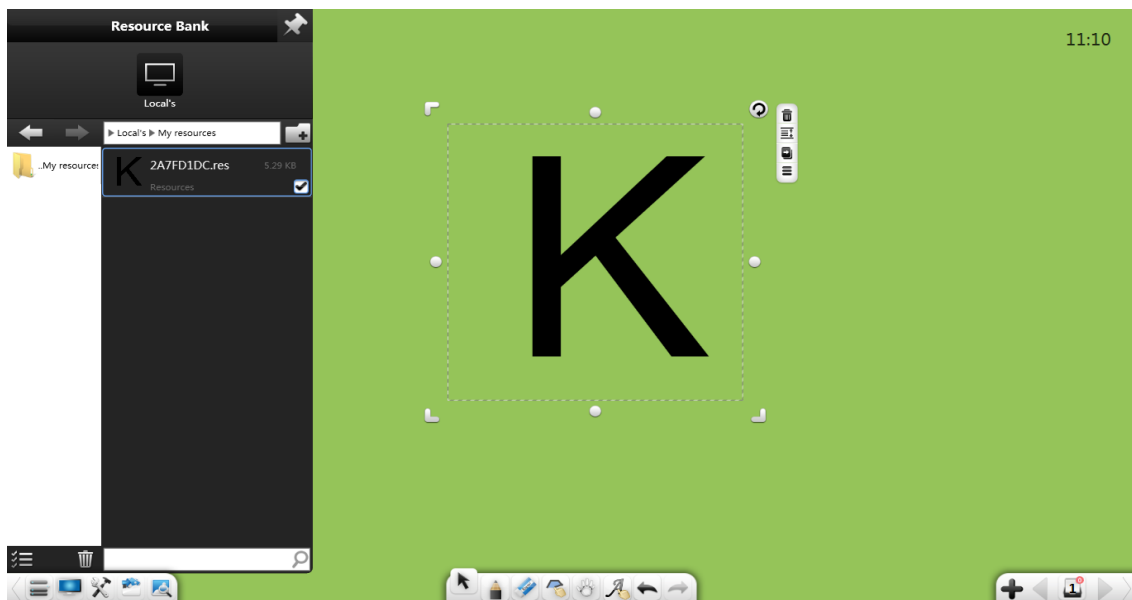



Figure 3-1-4-3 My Resources interface

- Click  to create a folder in **My Resources**. You can rename the created folder. The default folders cannot be renamed.

(3) My Favorites

Click  to quickly browse resources in the favorites folder. You can add navigation paths of folders to the favorites folder. See Figure 3-1-4-4.

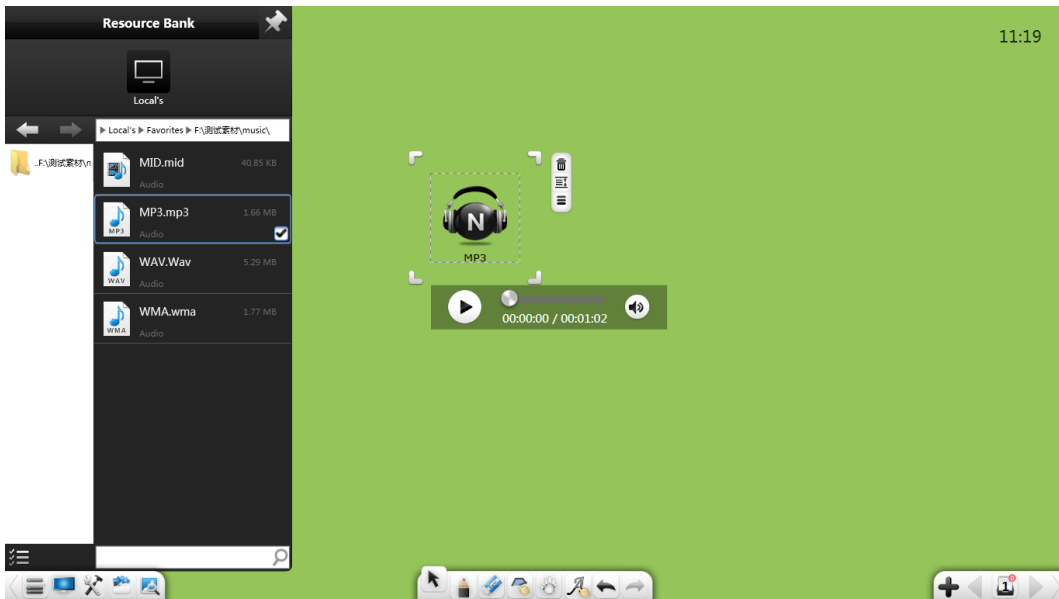

Figure 3-1-4-4 Favorites folder

(4) Desktop

Click  to browse resources on the desktop.

(5) Disk Resources

Click  to browse resources on the disks of the computer.

3.1.5 Image Browser

Click . Then the Image browser interface shown in Figure 3-1-5-1 is displayed. You can quickly search for information in Google or Bing.



Figure 3-1-5-1 Encyclopedia interface

1. Search: Select Bing or Google, enter keywords in the search box, and click

 . See Figure 3-1-5-2.

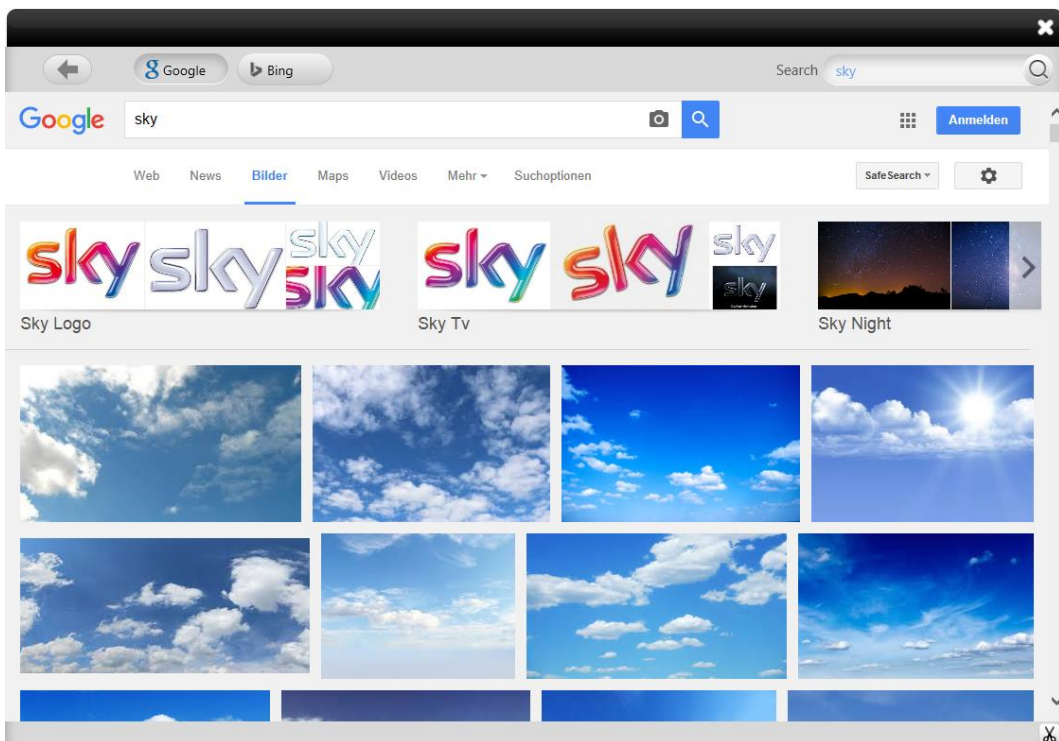



Figure 3-1-5-2 Search result

2. Screenshot: Click  in the lower right corner to take a screenshot of any area on the interface. You can insert the screenshot into the page.
3. Picture: Select Bing, search for a picture, and drag the picture to the page.
4. Click the back button on the left corner of a page to return to the previous page.

3.1.6 Select

Click . Then you can draw any closed graph or click an object on the interface and perform the following operations: moving, zooming, revolving, deletion, trimming, editing, taking screenshots of videos or audios, change the object level, setting animation effects, dragging the object to clone it, locking, setting the thickness and color, fill color, grouping (multiple objects), ungrouping, exporting pictures, audios, or videos to the local computer, adding pictures, audios, or videos to the resource library, editing hyperlinks, copy, cutting, pronouncing, and setting graph properties. See Figure 3-1-6-1.

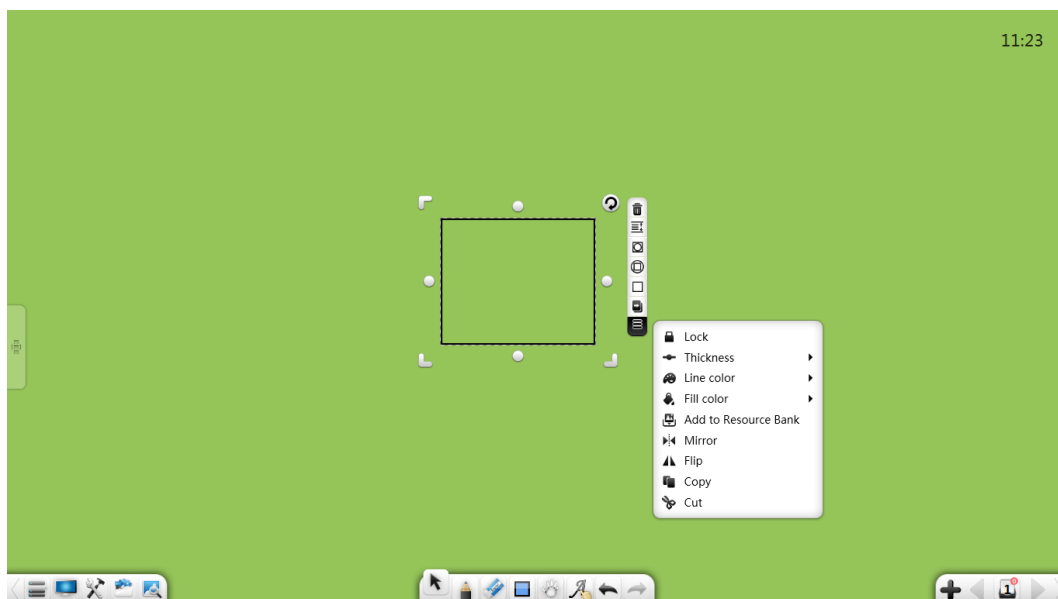

Figure 3-1-6-1 Selecting an object

Note:

- 1>You can perform the combination operation only when multiple objects are selected.
- 2.If multiple selected objects are combined and no object that is not combined is selected, the **Group** button changes to **Ungroup**. You can perform the ungrouping operation.
- 3>You can edit a hyperlink only when a single object is selected or the selected objects are grouped in preparation mode. You cannot edit hyperlinks in other modes.
- 4.You can set animation effects only in preparation mode.

(1) Align objects

If there are multiple objects on the page, when you drag an object, an edge line or the central line of the object is aligned with that of other objects. See Figure 3-1-6-2.

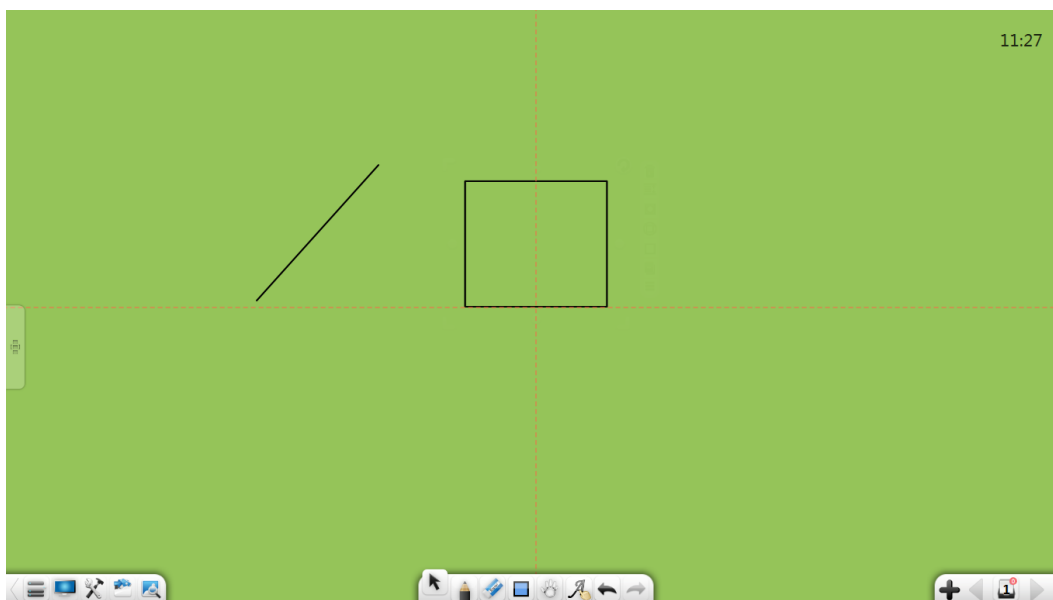

Figure 3-1-6-2 Aligning objects

(2) Touch operations

If the device supports multipoint touch, you can perform multipoint touch operations in the selected state, including 2-point page switching, 3- or 4-point zooming, and 5-point roaming.

(3) Move objects

In the selected state, you can click and drag an object to move it without selecting it.

3.1.6.1 Handwriting

Select a handwriting object and perform the following operations: moving, zooming, revolving, deletion, setting the object level, setting animation effects, dragging the object to clone it, locking, setting the thickness and color, grouping (multiple objects), ungrouping, adding the object to the resource library, editing a hyperlink, copy, and cutting. See Figure 3-1-6-1-1.



Figure 3-1-6-1-1 Selecting a handwriting object

1. Move: Click and drag the selected handwriting object to move it to any position. When you drag an object, its alignment line, the central line or an edge line, is automatically displayed. In the figure below, the central line is displayed.

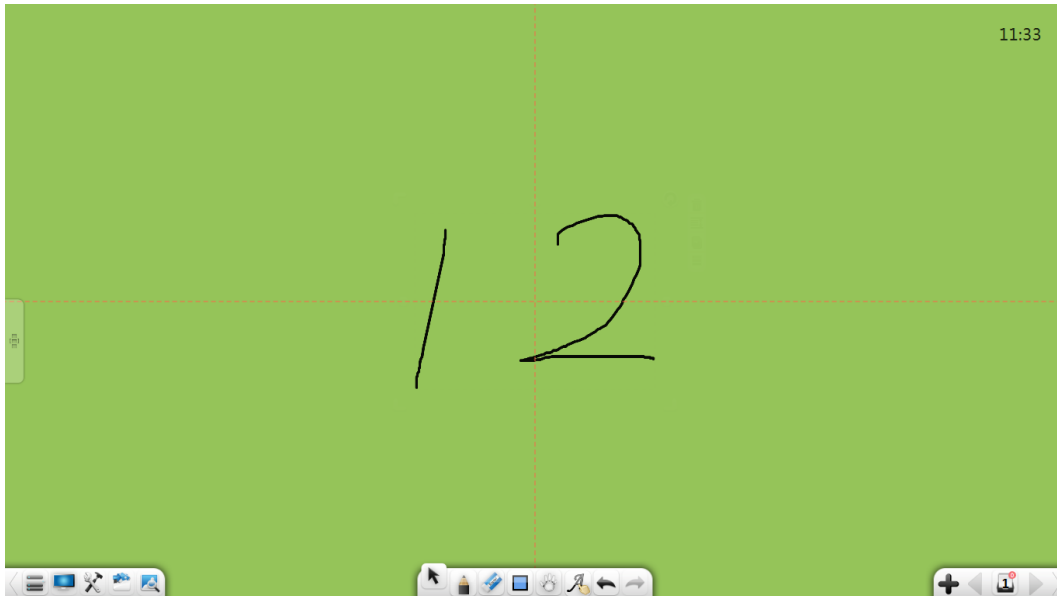















Figure 3-1-6-2 Alignment line

2. Zoom: Press and hold down , , and  to zoom in or out of the object in any direction.
3. Zoom based on an equal ratio: Press and hold down , ,  and Shift to zoom in or out the an object at an equal ratio.
4. Zoom in a single direction: Hold down  in any direction to zoom in or out of the object.
5. Revolve: Click  to revolve the selected handwriting object.
6. Touch: Move, zoom, or revolve the selected handwriting object in multipoint mode.
7. Delete: Click  to delete the selected handwriting object.
8. Line color: Click  to set the color of the selected handwriting object.
9. Set the object level: Click  to display a sub-menu, where you can set the levels of multiple objects (handwritings, lines, graphs, pictures, audios, and videos), such as moving upwards or downwards by one level, or moving to the top or bottom. If multiple objects overlap (at the same level) and the object not at the top is selected and moved, this object floats at the top.

After you release the mouse or touch other places, the object automatically returns to the original level.

10. Animation effect: In preparation mode, select a handwriting and click  to access the material editing window, or click  in the material editing window to switch to the interface for setting animation effects. See Figure 3-1-6-1-3.

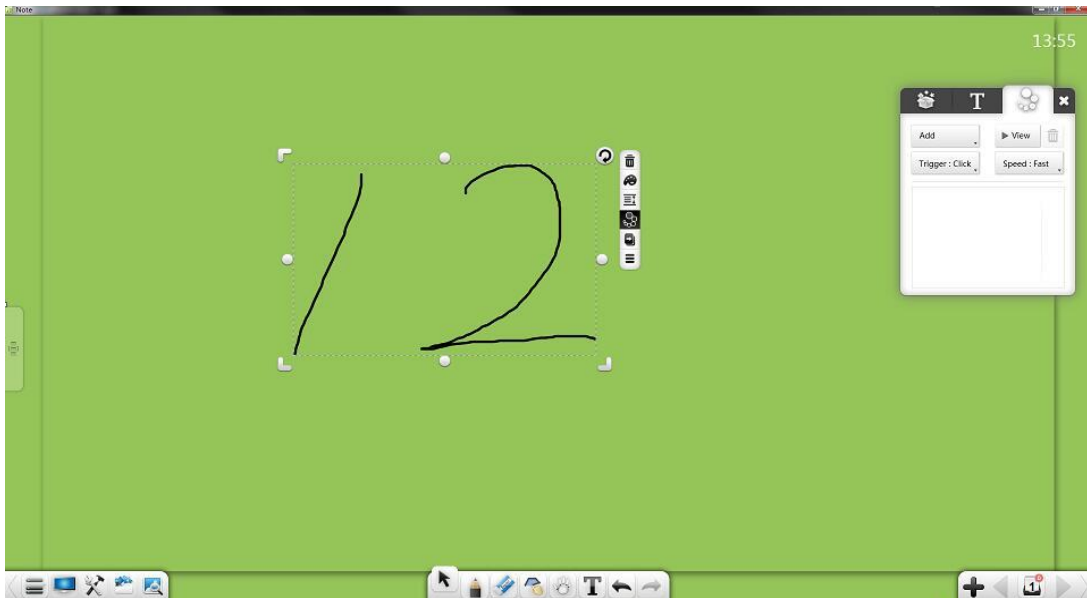



Figure 3-1-6-1-3 Setting animation effects

- a) Set animation: In the drop-down list for adding animation, select the entry and exit animation effects, including gradient, chessboard, erasure, and flame.
Note: After setting the entry/exit animation for an object, you need to select another object before setting another animation.
- b) Trigger mode: Select the preset animation, and select a trigger mode from the drop-down list. There are three trigger modes: click, simultaneous, and after.
- c) Play speed: After setting the animation, select a play speed, including high speed, medium speed, and low speed.
- d) Preview: Selected an added animation and click  to preview the animation.

e) Modify: Select an added animation and modify the animation effect, trigger mode, or play speed.

f) Delete: Select an added animation and click  to delete it.

g) Animation prompt: After adding animations, animation sequence numbers are displayed in the upper left corner of the corresponding objects. The animation quantity of the current page is displayed in the upper right corner of the page number. See Figure 3-1-6-1-4.

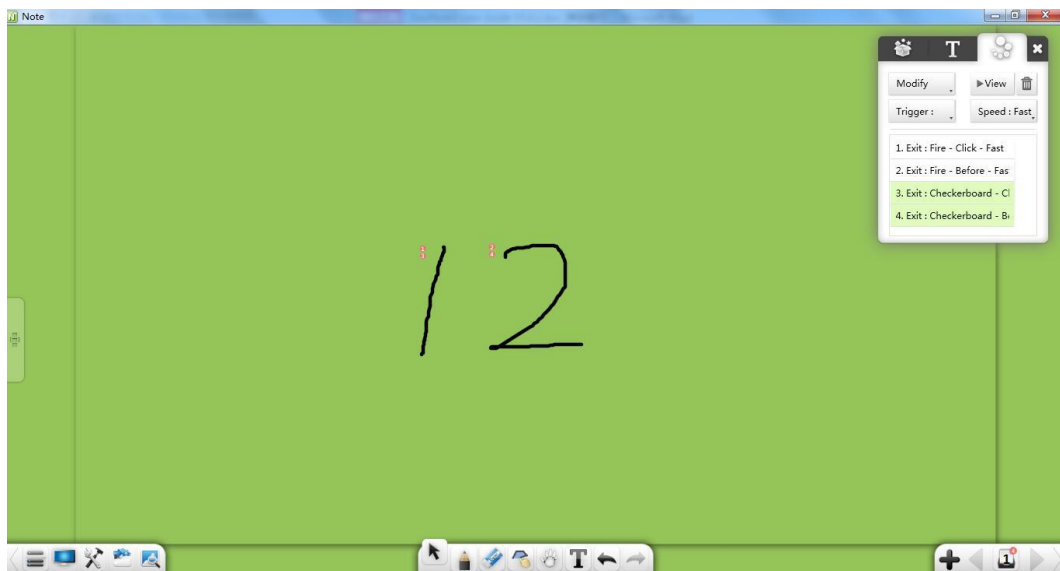









Figure 3-1-6-1-4 Animation prompt

11. Drag to clone: Click  to enter clone mode. In this mode, drag the selected handwriting to clone it. You can repeat the operation to clone the handwriting multiple times. Click this button again to exit clone mode.
12. More: Click  to display the object editing menu. You can perform the following operations: setting the thickness and color, grouping (multiple objects), ungrouping, adding the selected handwriting to the resource library, editing hyperlinks, copy, and cutting.
 - a) Lock: Click  to lock the selected object.
 - i) A locked object can only be deleted or roamed by the clearing operation. Other operations are ineffective for a locked object.

- ii) Click the lock button in the upper right corner of a locked object to unlock it.
- b) Thickness: Click  to set the thickness of the selected handwriting object.
- c) Group: Click  to group multiple objects, including handwritings, lines, graphs, pictures, audios, and videos. After multiple objects are grouped, you can select any object to select all of them.
- d) Ungroup: Click  to ungroup the objects, including handwritings, lines, graphs, pictures, audios, and videos. The ungrouping operation revokes only the last grouped object, excluding the objects that have been grouped earlier. For example, if you group A and B and then group AB and C, when you revoke the group of ABC, AB is ungrouped with C and the group AB is reserved. If you revoke the group of AB, A is ungrouped with B.
- e) Add to the resource library: Click  to add the selected handwriting to the resource library.
- f) Edit hyperlinks: Select a single object or multiple grouped objects and click . In the window shown in Figure 3-1-6-1-5, you can add a hyperlink to the selected object. The hyperlink can link to a file, network, text information, whiteboard page number, audio file, or small tool. (Note: After multiple objects are grouped, the original links are automatically deleted. You can set a hyperlink for the grouped objects.)

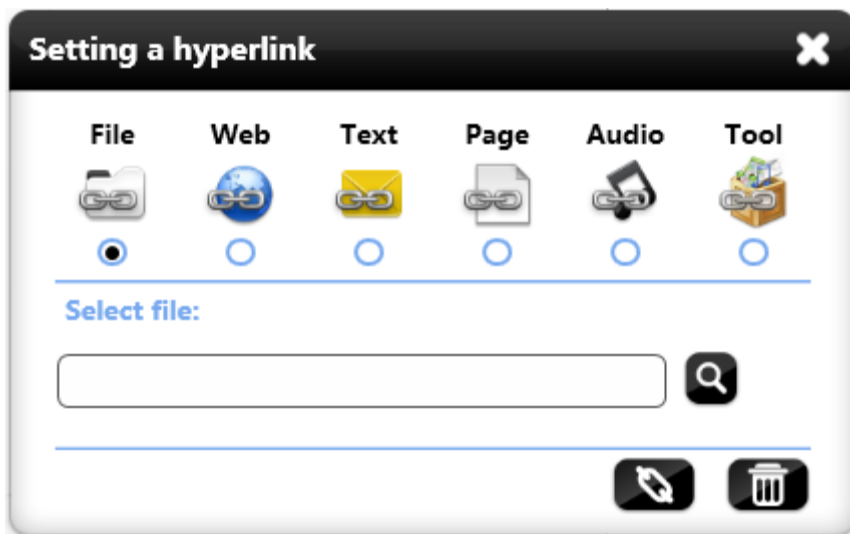









Figure 3-1-6-1-5 Editing a hyperlink

- i) File: Select  to link to a file. Search and select the file to be linked and click the link button.
- ii) Network: Select  to link to a website. Enter the website address and click the link button.
- iii) Text information: Select  to link to text information. Enter text information and click the link button.
- iv) Whiteboard page: Select  to link to a whiteboard page. Enter a valid whiteboard page number and click the link button.
- v) Audio file: Select  to link to an audio file. Search and select the audio to be linked and click the link button.
- vi) Small tool: Click , select a tool to be linked, and click the link button.
- vii) Link: Click . Select an object and the link button is displayed below the object. You can click the link button to access the linked contents. See Figure 3-1-6-1-6.

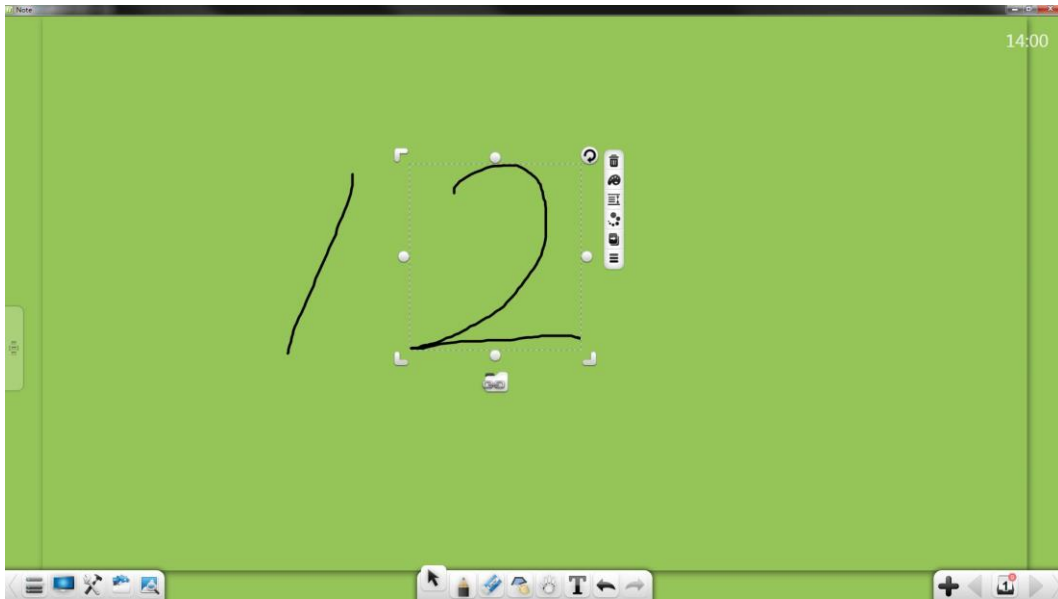





Figure 3-1-6-1-6 Showing the hyperlink button

- viii) Delete hyperlinks: Click  to revoke a hyperlink and close the current window.
- g) Copy: Click  to copy the selected handwriting. The handwriting copy can be pasted as a picture at any position in a Word or PPT document, or in the original format on another page. For details, see section 3.1.1.3.4.
- h) Cut: Click  to cut the selected handwriting. The cut handwriting can be pasted as a picture at any position in a Word or PPT document, or in the original format on another page. For details, see section 3.1.1.3.4.

3.1.6.2 Line

Select a line object and perform the following operations: moving, zooming, revolving, deletion, setting the object level, setting animation effects, dragging the object to clone it, locking, setting the thickness and color, grouping (multiple objects), ungrouping, adding the object to the resource library, editing a hyperlink, copy, and cutting. See Figure 3-1-6-2-1. The functions are the same as those for handwriting objects. For details, see section 3.1.6.1.

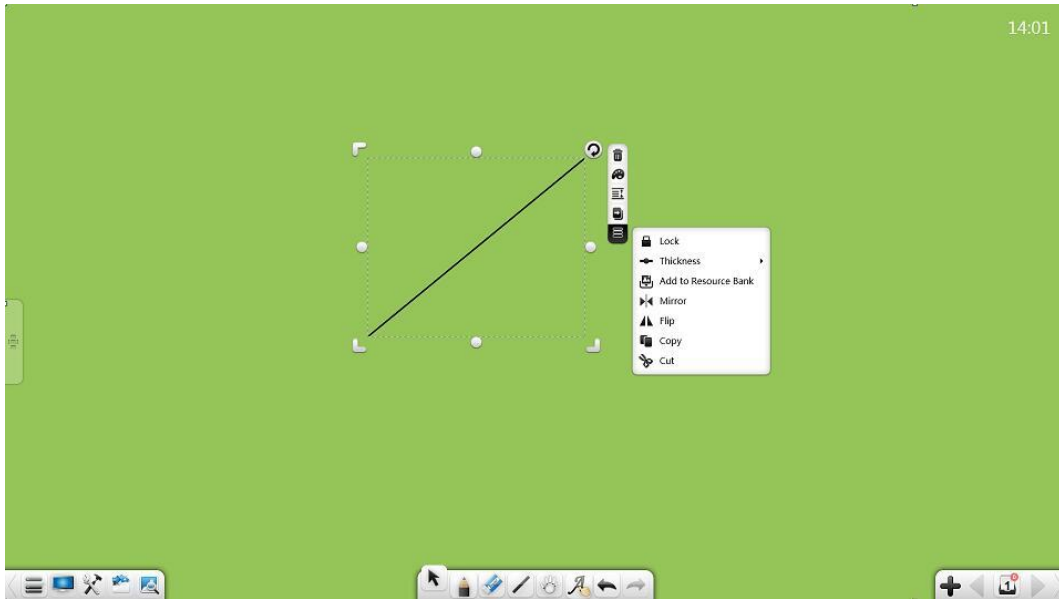

Figure 3-1-6-2 Selecting a line

3.1.6.3 Planar Graph

Select a planar graph and perform the following operations: moving, zooming, revolving, deletion, setting the object level, setting animation effects, dragging the object to clone it, locking, setting the thickness and color, fill color, grouping (multiple objects), ungrouping, adding the object to the resource library, editing a hyperlink, copy, cutting, and setting rectangular circumcircle, rectangular double-edge-contact circle, triangular in-circle, triangular circumcircle, center of circle, and radius. See Figure 3-1-6-3-1. You can set the circumcircle and double-edge-contact circle to be displayed only in a rectangle, the in-circle and circumcircle to be displayed only in a triangle, and the radius and center of circle to be displayed only in a circle.

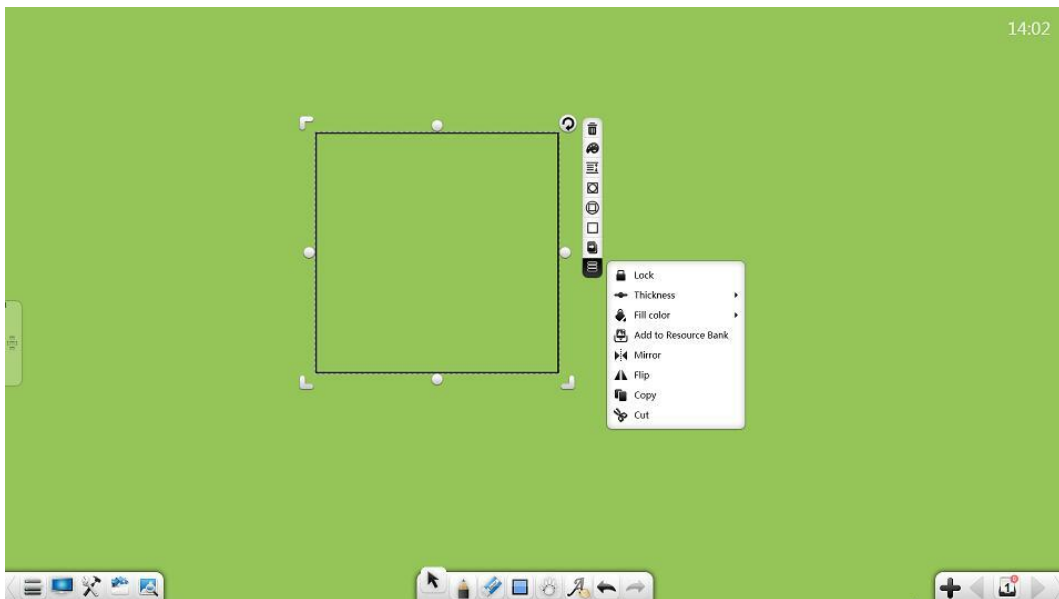



Figure 3-1-6-3-1 Selecting a graph

1. The functions of moving, zooming, revolving, deletion, setting the object level, setting animation effects, dragging the object to clone it, locking, setting the thickness and color, grouping (multiple objects), ungrouping, adding the object to the resource library, editing a hyperlink, copy, and cutting are the same as those for handwriting objects. For details, see section 3.1.6.1.
2. Fill color: Click  to fill color for a single graph. Select a color and then the graph is automatically filled with the color. You can also adjust the transparency of the fill color. See Figure 3-1-6-3-2.

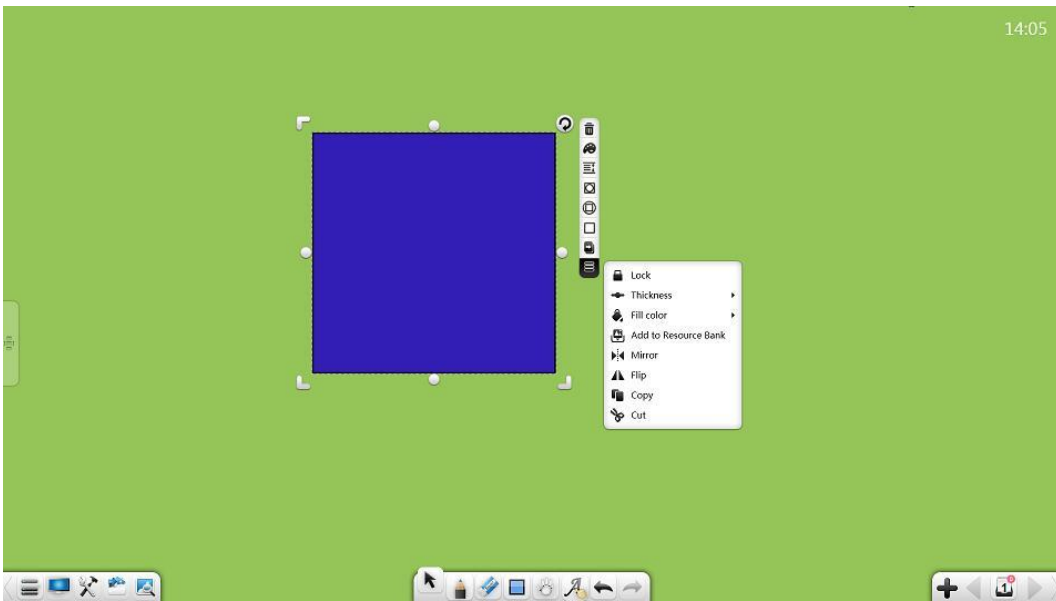



Figure 3-1-6-3-2 Fill color

3. Rectangular double-edge-contact circle. Click  to set a double-edge-contact circle in a rectangle. See Figure 3-1-6-3-3.

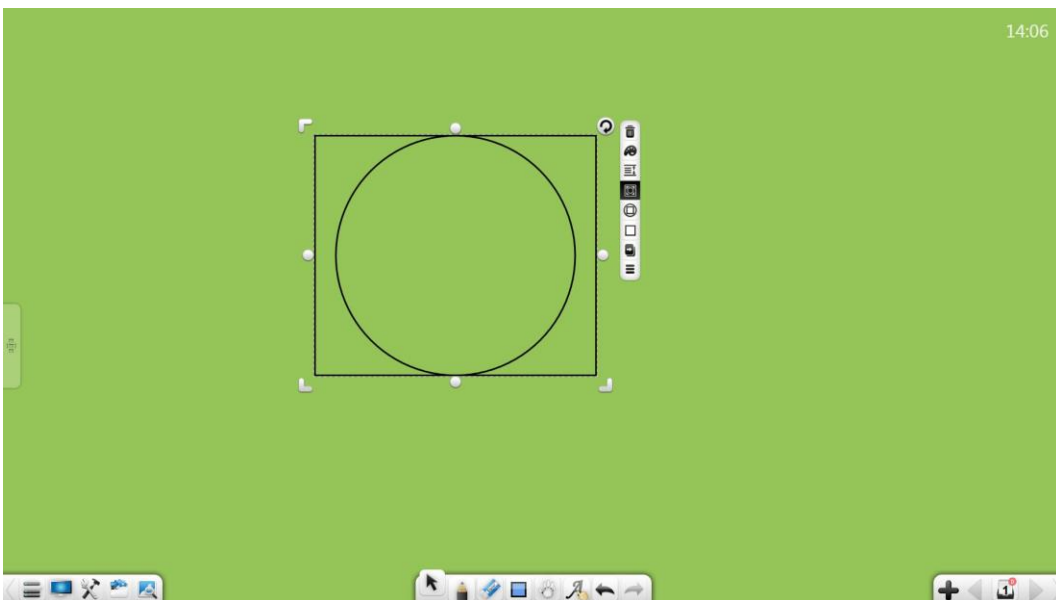

Figure 3-1-6-3-3 Rectangular double-edge-contact circle

4. Rectangular circumcircle. Click  to set a circumcircle in a rectangle. See Figure 3-1-6-3-4.

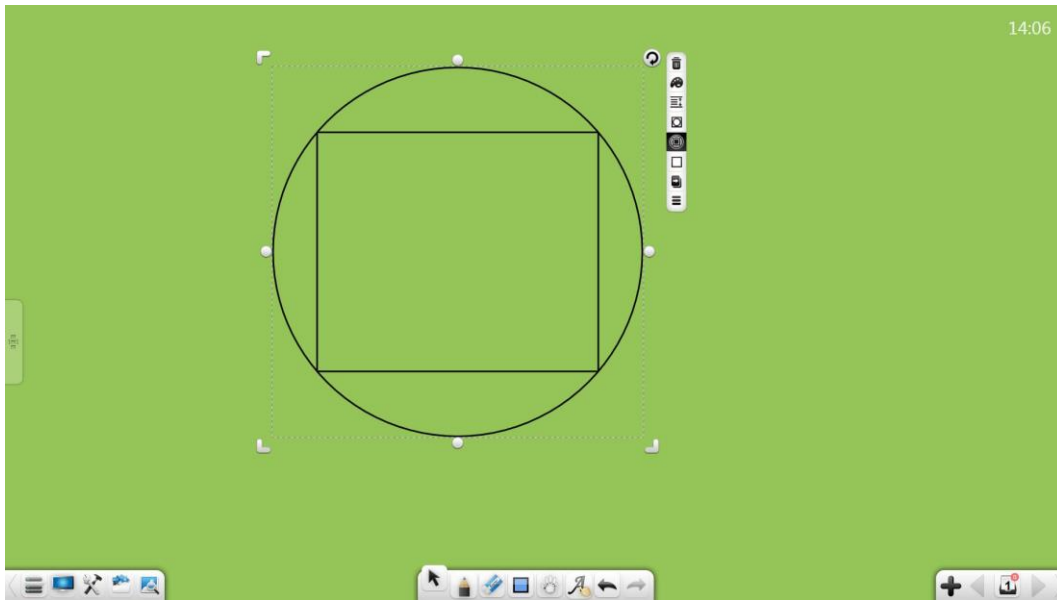



Figure 3-1-6-3-4 Rectangular circumcircle

5. Triangular incircle. Click  to set an incircle in a triangle. See Figure 3-1-6-3-5.

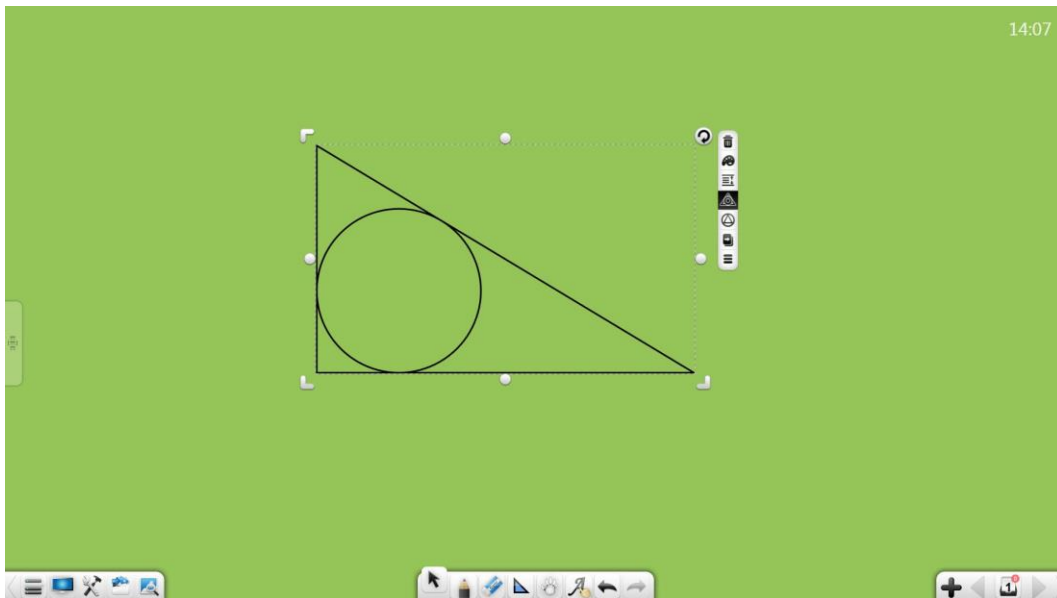



Figure 3-1-6-3-5 Triangular incircle

6. Triangular circumcircle. Click  to set a circumcircle in a triangle. See Figure 3-1-6-3-6.

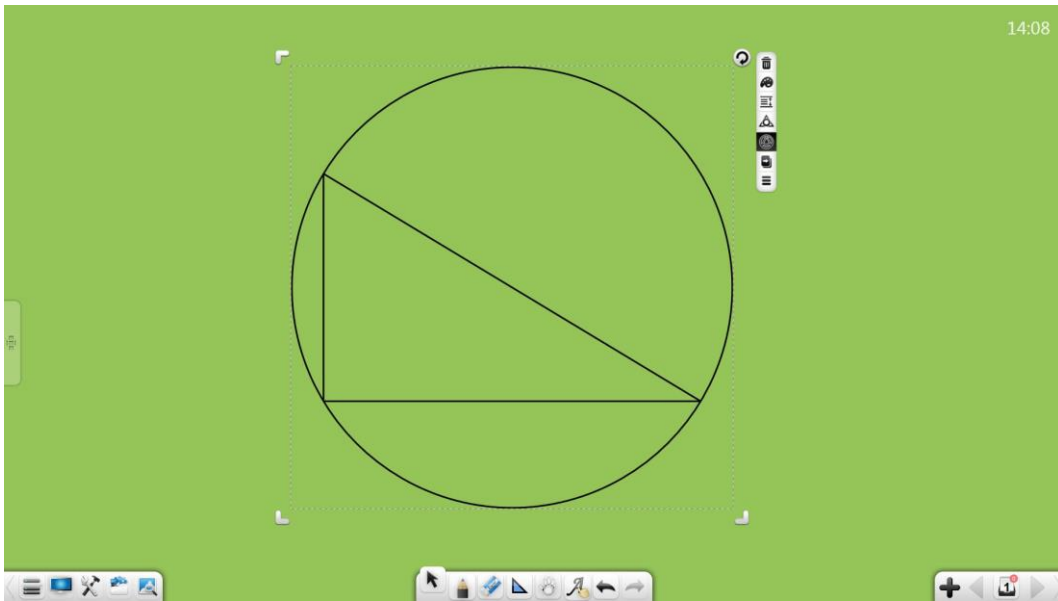

Figure 3-1-6-3-6 Triangular circumcircle

7. Show the center of circle: Click  to show the center of a circle. See Figure 3-1-6-3-7.

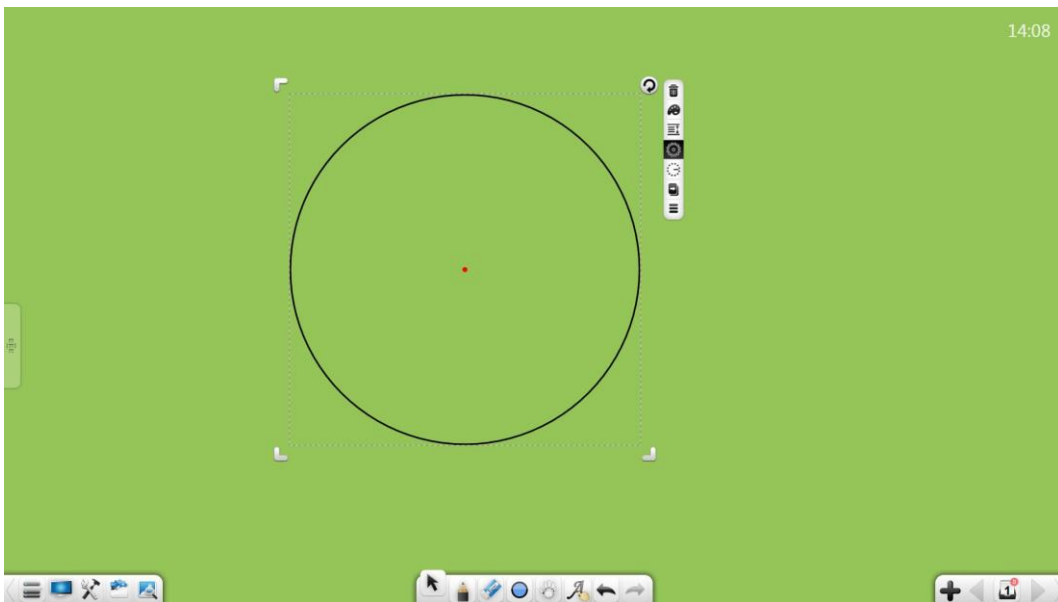



Figure 3-1-6-3-7 Center of circle

8. Show the radius: Click  to show the radius of a circle. See Figure 1-6-3-8.

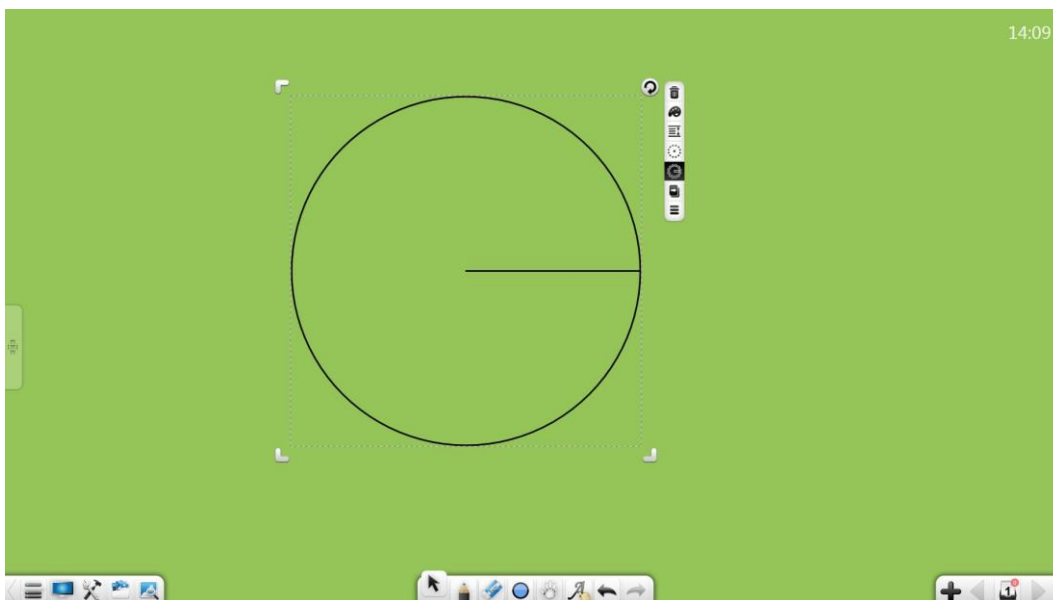

Figure 3-1-6-3-8 Radius of circle

3.1.6.4 3D Graph

In math mode, select a 3D graph and perform the following operations: moving, zooming, revolving, deletion, setting the object level, setting animation effects, dragging the object to clone it, locking, setting the thickness and color, fill color, grouping (multiple objects), ungrouping, adding the object to the resource library, editing a hyperlink, copy, and cutting. See Figure 3-1-6-4. The functions are the same as those for planar graphs. For details, see section 3.1.6.3.

14:10

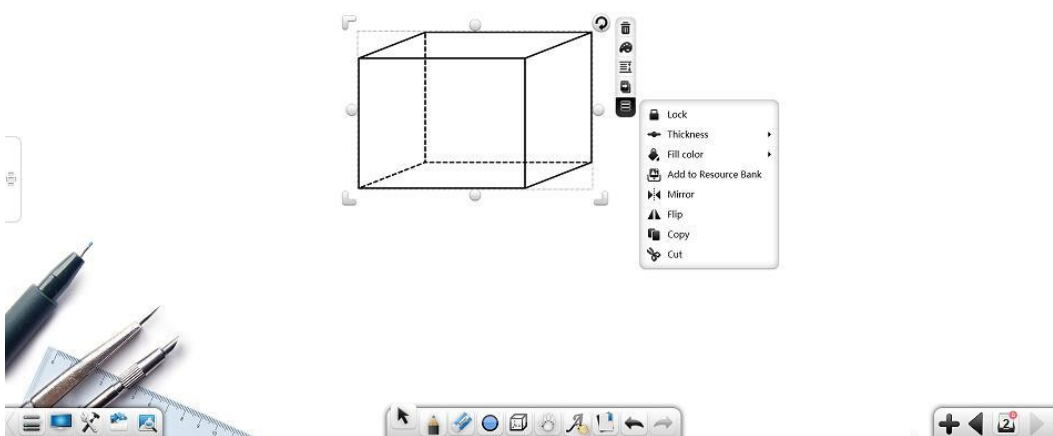

Figure 3-1-6-4 Selecting a 3D graph

3.1.6.5 Text

Select a text object and perform the following operations: moving, zooming, revolving, deletion, editing, setting the object level, combining, setting animation effects, dragging the object to clone it, locking, grouping (multiple objects), ungrouping, adding the object to the resource library, editing a hyperlink, copy, cutting, and reading. See Figure 3-1-6-5-1. The software supports editing and reading only when a single text object is selected. Combining is supported only when multiple text objects are selected.

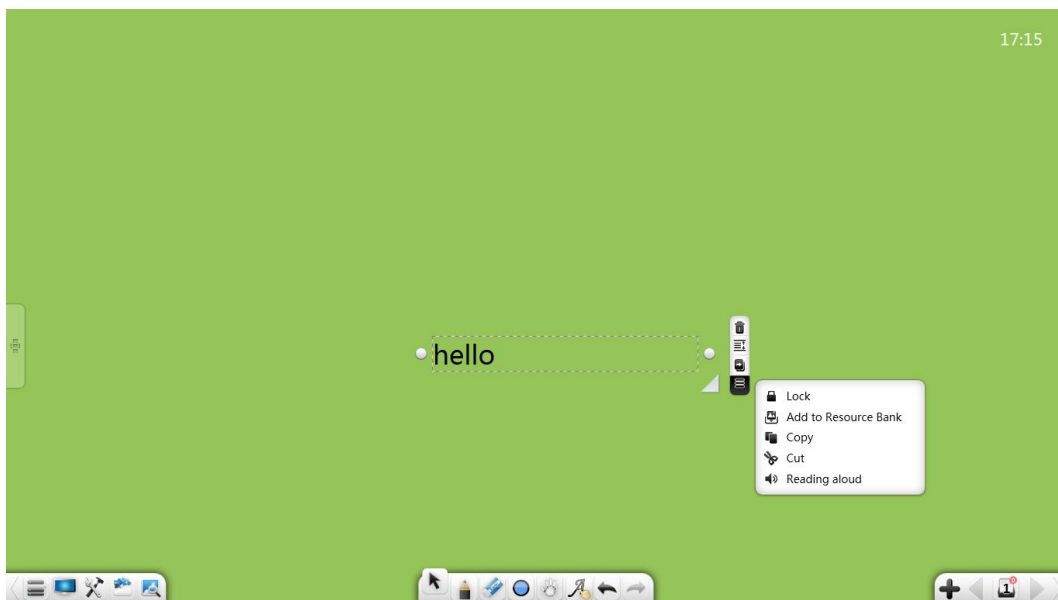



Figure 3-1-6-5 Selecting a text

1. The functions of moving, zooming, revolving, deletion, setting the object level, setting animation effects, dragging the object to clone it, locking, grouping (multiple objects), ungrouping, adding the object to the resource library, editing a hyperlink, copy, and cutting are the same as those for handwriting objects. For details, see section 3.1.6.1.
2. Edit the text: Select and click the text to enter the text editing state. You can edit the selected text.
3. Merge texts: Click  to merge two or more selected groups of texts. The selected texts will be automatically arranged behind the first group of texts.

a) Reserve the original format: Select and click **Tt** to reserve the original format. That is, the original formats of the texts are reserved.

b) Merge formats: Select and click **TT** to merge the formats. The text font, size, and color are the same as those of the first group of texts.

4. Read: Click  to read the selected text.

3.1.6.6 Picture

Select a picture object and perform the following operations: moving, zooming, revolving, deletion, trimming, setting the object level, setting animation effects, dragging the object to clone it, locking, grouping (multiple objects), ungrouping, adding the object to the resource library, editing a hyperlink, copy, and cutting. See Figure 3-1-6-6-1. You can set a picture as the background or export the picture only when a single picture object is selected. (Note: Some functions are available just when the software is in preparation mode.)

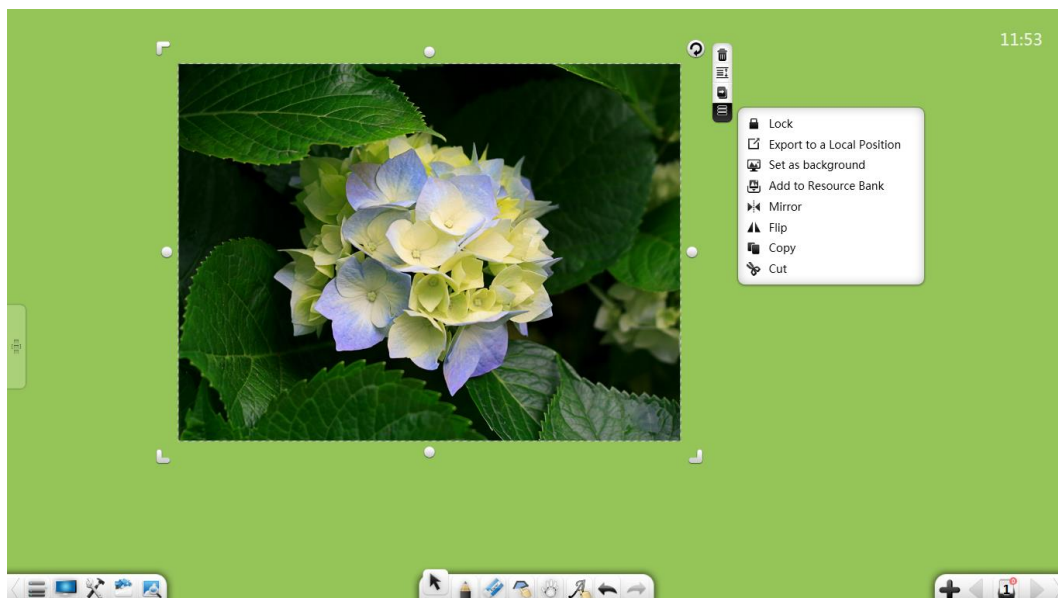



Figure 3-1-6-6-1 Selecting a picture

1. The functions of moving, zooming, revolving, deletion, setting the object level, setting animation effects, dragging the object to clone it, locking, grouping (multiple objects), ungrouping, adding the object to the resource library, editing a hyperlink, copy, and cutting are the same as those for handwriting objects. See Figure 3-1-6-2. For details, see section 3.1.6.1.

2. Trim: In preparation mode, click  to trim the current picture. See Figure 3-1-6-6-2. Click  to display the trimmed picture on the page and  to cancel the trim operation.

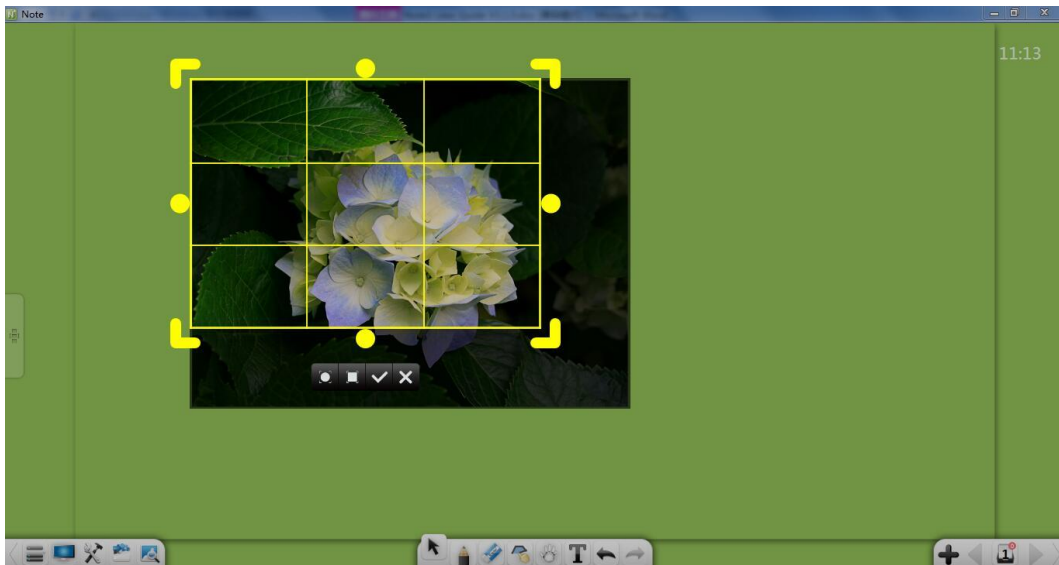

Figure 3-1-6-6-2 Trimming pictures

3. Export to the local computer: Click  to export the selected picture in the original format.

3.1.6.7 Audio/Video

Select an audio/video object and perform the following operations: play, pause, dragging the progress bar, adjusting the volume, display in full screen, moving, zooming, deletion, taking screenshots, setting the object level, setting animation effects, locking, grouping (multiple objects), ungrouping, exporting, adding to the resource library, copy, and cutting. See Figure 3-1-6-7. You can play, pause, stop, drag the progress bar, take screenshots, and export the audio/video in original format only when a single audio/video object is selected.

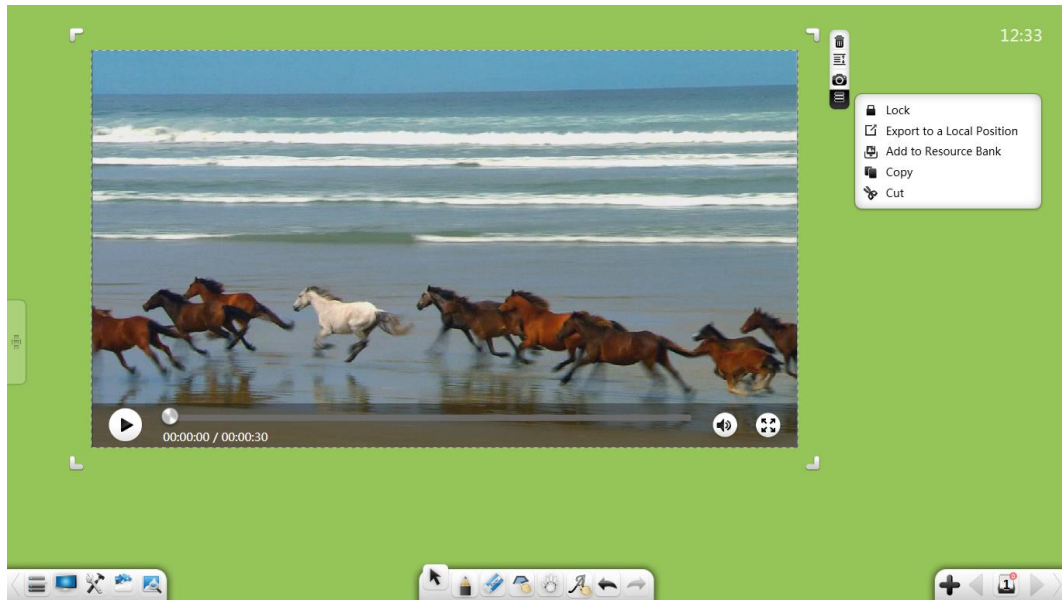







Figure 3-1-6-7 Selecting an audio/video

1. The functions of moving, zooming, deletion, setting the object level, setting animation effects, locking, grouping (multiple objects), ungrouping, exporting, adding the object to the resource library, copy, and cutting are the same as those for graph objects. For details, see section 3.1.6.6.

Note: Audio and video objects do not support revolving.

2. Play: Click  to play the selected audio/video.
3. Pause: Click  to pause the audio/video being played.
4. Drag the progress bar: Drag the progress bar of the audio/video being played to adjust the play position.
5. Adjust the volume: Click . Drag the volume scrollbar to adjust the volume.
6. Full screen: Click  to display the video in full screen mode and  to exit full screen mode.
7. Screenshot: Click  to take a screenshot of the current audio/video and insert the screenshot into the software interface as a picture.

3.1.6.8 Compass Graph

Select a graph (including arcs and sectors) drawn by using a compass and

perform the following operations: moving, zooming, revolving, deletion, setting the object level, setting animation effects, dragging the object to clone it, locking, setting the thickness and color, grouping (multiple objects), ungrouping, adding the object to the resource library, editing a hyperlink, copy, and cutting. See Figure 3-1-6-8. The functions are the same as those for handwriting objects. For details, see section 3.1.6.1.

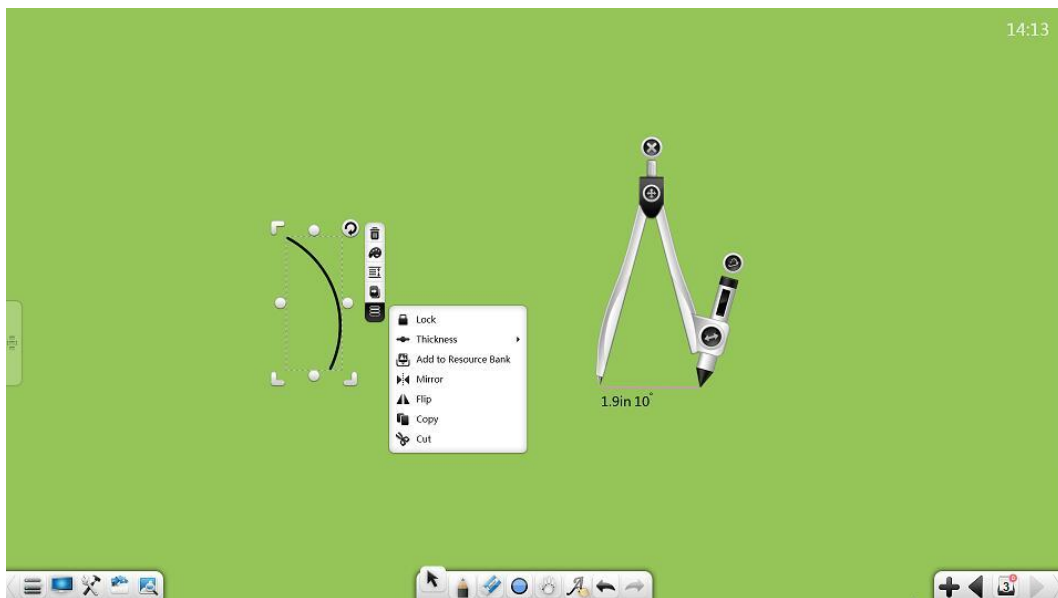

Figure 3-1-6-9 Selecting a compass graph

3.1.7 Handwriting









Click  to access the pen setup window. See Figure 3-1-7-1. You can select a paintbrush and set the thickness and color of handwritings. There are many types of paintbrushes including the marker, Paintbrush, Highlighter, Calligraphy, laser pen, stamp pen, and Image Pen.



Figure 3-1-7-1 Paintbrush

1. Marker: Click  to use the Marker. The default color is black and the handwriting is thin.
2. Paintbrush: Click  to use the Paintbrush. The default color is black and the handwriting is thin.
3. Highlighter: Click  to use the Highlighter. The default color is black. When you write using the brush, the thickness varies according to the writing angle. Lateral lines are thick and vertical lines are thin. Intuitive writing experience is delivered.
4. Calligraphy: Click  to use the Calligraphy. The default color is black. When you write using the Calligraphy, the thickness will change in real time according to the writing speed. The handwriting will be thin when the writing speed is high and be thick when the writing speed is low. Intuitive writing experience is delivered.
5. Laser pen: Click  to use the laser pen. The default color is black. When you write using the laser pen, the handwriting will fade away.
6. Stamp pen: Click  to use the stamp pen. The handwriting of the stamp pen is graph. There are totally eight types of graphs. You can define graphs as required.

7. 7b \Z'eZc09aX'  id'j hZ'i] Z' b \Z'eZc\$Ndj 'Xvc'X] ddhZ'e Xij g'zh'Vh'i
i] Z'] VcYI g'f'e\ 'd[i] Z' b \Z'eZc\$Ndj 'Xvc'Vhd'YZ['eZ'e Xij g'zh'Vh'i] Z'
] VcYI g'f'e\ 'd[i] Z' b \Z'eZc\$

8. I] X' cZhh07 [iZghZaXi e\ 'V'eZc"ndj 'Xvc'haYZ'i] Z'i] X' cZhh'Wgid'VYj hi'
i] Z'] VcYI g'f'e\ 'i] X' cZhh\$ ZZ' <^j g'z') # # # (\$



<^j g'z') # # # ('7Yj hi e\ '] VcYI g'f'e\ 'i] X' cZhh'

9. 9dadg07 [iZghZaXi e\ 'V'eZc"XaX' 'i] Z' Xdadge X' Zgdc'i] Z' g\] i' VcY' hZaXi'
Vcn'Xdadg\$7 'YgdeeZg'h'egdk'YZY\$Ndj 'Xvc'hZaXi' Vcn'Xdadgdc'i] Z' hd[il 'Vg'z'
e'Zig'VXZ'dgXdadge X' ZgWh'i] Z' YgdeeZg\$

10. Cj a'ed'e'i'l g'f'e\ 'd] Z' hd[il 'Vg'z' Vadi h'ndj 'id'eZgdg' b'j a'ed'e'i'l g'f'e\ '
WhZY'dc'i] Z' c'j b WZgd['deZgi'dc'ed'e'h'hj eedgZY'Wh'i] Z' idj X] '[g/b Z\$



) \$\$; g/hZg

9aX'  id'hZaXi'i] Z' Zg/hZg\$8n'YZ[Vj a" B'eZ' ; g/hZg'h'hZaXiZY"Vh'h] dl' c'
e' <^j g'z') # # . \$ I] Z' dei'dch' B'eZ' ; g/hZg' i Z'aXi' ; g/hZg' VcY' 9a'Vg'eV\Z' Vg'z'
Vkv'a'WZ\$



<^j g'z') # # . ; g/hZg

1. B'eZ' ; g/hZg09aX'  id'hZaXi'i] Z' B'eZ' ; g/hZgb dYZ\$e'i] h'b dYZ"ndj'
Xvc'Zg/hZ'] VcYI g'f'e\ 'd['Xdb b dc'eZch"eXaj Y'e\ 'i] Z'] VgY# 'eeZY'eZc"
] ^] a\] iZg'l g'f'e\ 'Wg'h] "VcY' Wg'h] \$

2. Select Eraser: Click  to select the **Select Eraser** mode. In this mode, you can erase the selected handwriting of common pens (hard-tipped pen, highlighter, writing brush, and brush), lines, graphics, three-dimensional graphics, texts, images, video and audio.
3. Clear page: slide  to the right to clear all content on the current page.
4. Gesture Erasing: Touch the screen with a three-finger-sized touch area to enable the gesture erasing function and call the eraser. In this mode, you can erase the handwriting of all types of pens.

3.1.9 Shape

Click  to display the shape screen. By default, the Shape Recognizer mode is selected, Line Weight is set to Thin, and Line Color is set to Black, as shown in Figure 3-1-9. You can set the shape type, frame/line thickness, frame/line color, and filled geometric figures. The figure types include Shape Recognizer, Circle, Ellipse, Parallelogram, Right Triangle, Trapezoid, Isosceles Triangle, Rectangle, Rubber Band, Dotted Rubber Band, Dotted Line, Wave Line, Arrow, and Line Segment.

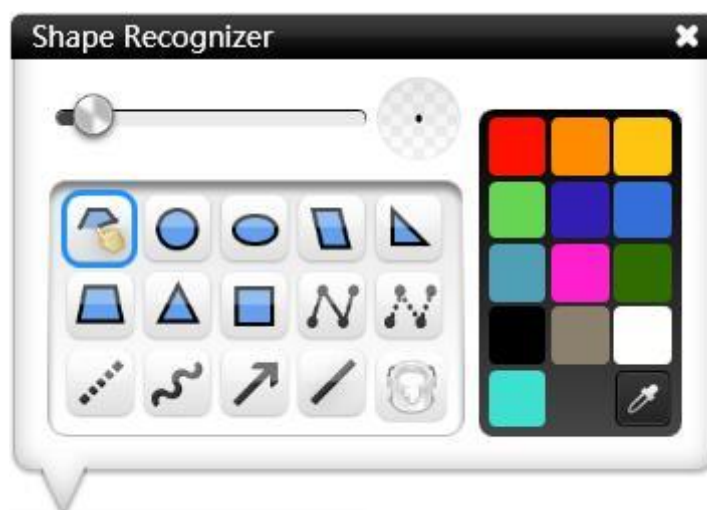



Figure 3-1-9 Figure tools

3.1.9.1 Geometric Figures

The geometric figures include Smart Recognition, Circle, Ellipse, Parallelogram, Right Triangle, Isosceles Trapezoid, Isosceles Triangle, and Rectangle.

1. Shape Recognizer: Click  to enable the Shape Recognizer function that can recognize line segment, angle (closed angle and obtuse angle), arrow, triangle, quadrilateral, ellipse, and circle. Figures drawn on the screen can be automatically recognized, as shown in Figure 3-1-9-1. When no figure is recognized, the system displays a prompt dialog box indicating that no figure is recognized, and this prompt dialog box is automatically closed in 1s.

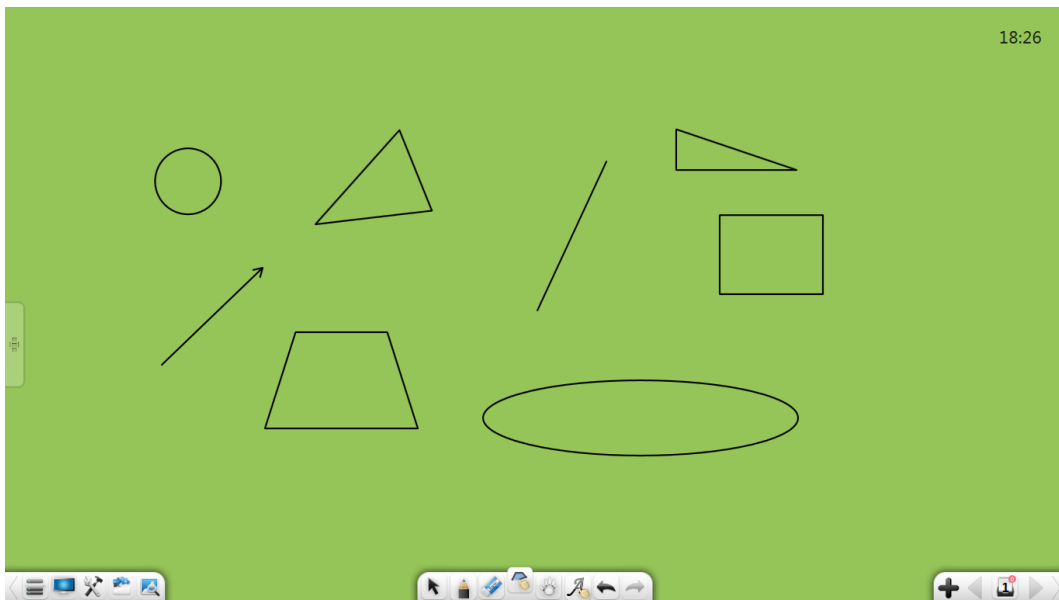









Figure 3-1-9-1 Figure recognition effect



- a) Line segment: When you draw a line on the screen, it is automatically recognized as a line segment.
- b) Angle: When you draw a figure with its two sides in any angle, it is automatically recognized as an angle.
- c) Arrow: When you draw a line segment with a recurvature at each side to any direction (complete this operation at a time), it is automatically recognized as an arrow.

- d) Triangle: When you draw a closed triangle (including the closed angle, right angle, and obtuse angle), it is automatically recognized as a triangle
- e) Quadrilateral: When you draw a closed quadrilateral, it is automatically recognized as a quadrilateral.
- f) Ellipse: When you draw a closed ellipse, it is automatically recognized as an ellipse.
- g) Circle: When you draw a closed circle, it is automatically recognized as a circle.

2. Circle: Click  to draw a circle. After the drawing is completed, the circle is selected by default.
3. Ellipse: Click  to draw an ellipse. After the drawing is completed, the ellipse is selected by default.
4. Parallelogram: Click  to draw a parallelogram. After the drawing is completed, the parallelogram is selected by default.
5. Right Triangle: Click  to draw a right triangle. After the drawing is completed, the right triangle is selected by default.
6. Isosceles Trapezoid: Click  to draw an isosceles trapezoid. After the drawing is completed, the isosceles trapezoid is selected by default.
7. Isosceles Triangle: Click  to draw an isosceles triangle. After the drawing is completed, the isosceles triangle is selected by default.
8. Rectangle: Click  to draw a rectangle. After the drawing is completed, the rectangle is selected by default.

3.1.9.2 Line

The lines include Solid Rubber Band, Dotted Rubber Band, Dotted Line, Wave Line, Arrow, and Line Segment.

1. Solid Rubber Band: Click  to draw a solid rubber band.
 - a) Drawing a line segment: Click the screen. When a blue operation point  is displayed, drag the blue operation point to draw the line segment.
 - b) Adjusting the line segment: Click the blue operation point. The operation point is changed to a black operation point , which can be used to adjust the length and position of the line segment.
 - c) Switching over the operation point: Click the black operation point again, so that it is changed to the blue operation point. Operation points are available on both ends of the line segment, as shown in Figure 3-1-9-2-1.

3-1-9-2-1.

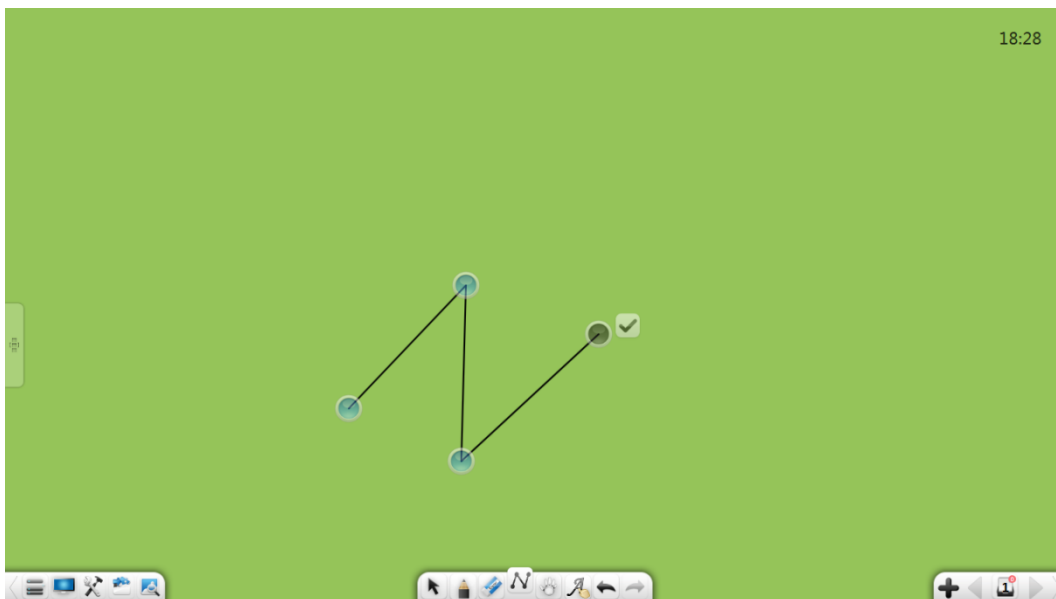

Figure 3-1-9-2-1 Rubber band tool

- d) Magnifier: When drawing a line segment, the magnifier is displayed at each endpoint. You can view the connection between lines clearly. See Figure 3-1-9-2-2.

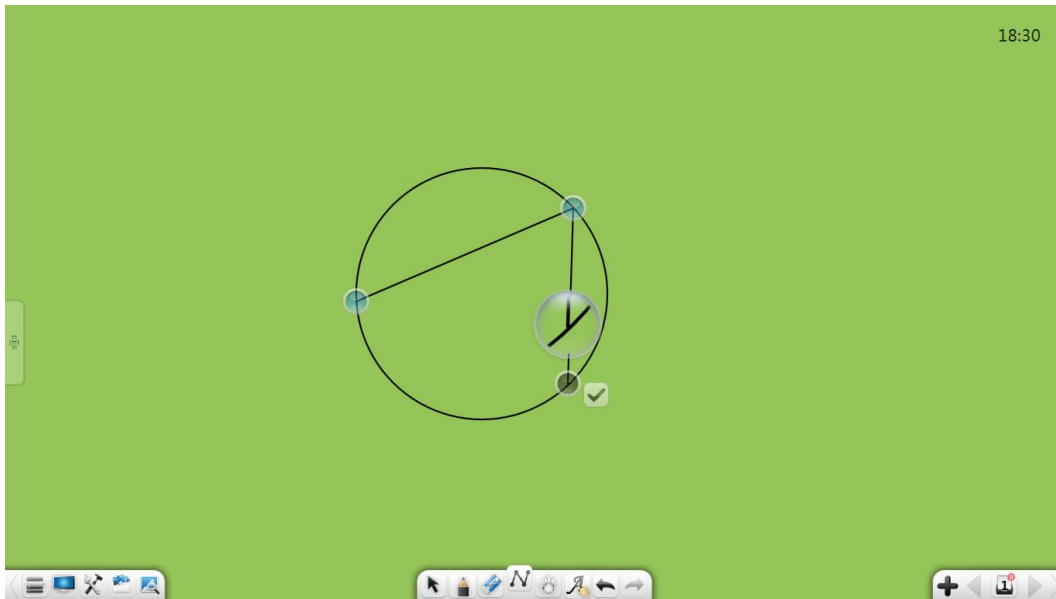









Figure 3-1-9-2-2 Magnifier displayed in drawing line segments using a rubber band

- e) Completing the drawing: Click  to complete the drawing. After the drawing is complete, the drawn figure cannot be modified.
2. Dotted Rubber Band: Click  to draw the dotted rubber band. For details, see the drawing steps in "① Solid Rubber Band".
3. Dotted Line: Click  to draw a dotted line. After the drawing is completed, the dotted line is selected by default.
4. Wave Line: Click  to draw a wave line. After the drawing is completed, the wave line is selected by default.
5. Arrow: Click  to draw an arrow. After the drawing is completed, the arrow is selected by default.
6. Line Segment: Click  to draw a line segment. After the drawing is completed, the line segment is selected by default.

3.1.9.3 Properties

Before drawing, you can set the thickness and color of the lines or frame. Then you can set the fill color of a drawn geometric figure. After the object in which the geometric figure is applied, you can change the thickness and color of its lines or frame.

1. Thickness of lines/frames: After you select a figure type, you can slide the slider for the line/frame thickness to change the thickness of the line/frame.
2. Color of lines/frames: After you select a figure type, you can click the color palette on the right to set the line color. You can select any color on the page or the color picker by the dropper.
3. Filled color: Click  to select the filled color. You can select any color on the page or the color picker by the dropper.

3.1.10 Roaming





After you click , click the current page (or left-click the page) and move the current page. Then, click  again to display the navigation chart. You can quickly locate the positions, browse the location information on the current page and adjacent pages, and adjust the percentage on the navigation chart. See Figure 3-1-10.



Figure 3-1-10 Navigation chart

1. Browse: Click at any position in the navigation window. The corresponding position is displayed automatically.
2. Adjust the display proportion: Drag the scrollbar in the page roaming navigation window to resize the page.
3. 100% display: Click **100%** to display the page in the 100% proportion.
4. Restore full screen: Click  to restore full screen.
5. Touch: You can zoom the screen by touching two points in the roaming state.
6. Gesture roaming: Long touch the screen at two points for 0.5s. The page jitters twice to enable the gesture roaming function, which allows you to roam the current page. If there is no operation in 0.5s, the page jitters twice to disable the gesture roaming function.

3.1.11 Handwriting Recognition

Click  to enable the handwriting recognition function and a quill-pen is displayed. After writing on the page, the handwriting is automatically recognized and displayed on the page. See 3.1.13.3 "Handwriting Recognition."

3.1.12 Cancel

Click  to cancel the last operation. This option is unavailable when no drawing operation is performed on the selected object.

3.1.13 Redo

Click  to restore the last cancel operation. This option is unavailable when no cancel operation is performed on the selected object.

3.1.14 Add Page

Click  to add a new page when the current page is the last page.

3.1.15 Previous Page

Click  to go to the previous page of the current page when the current page is not the first page.

3.1.16 Page Management

Click  to view all the page information of the file, as shown in Figure 3-1-15.

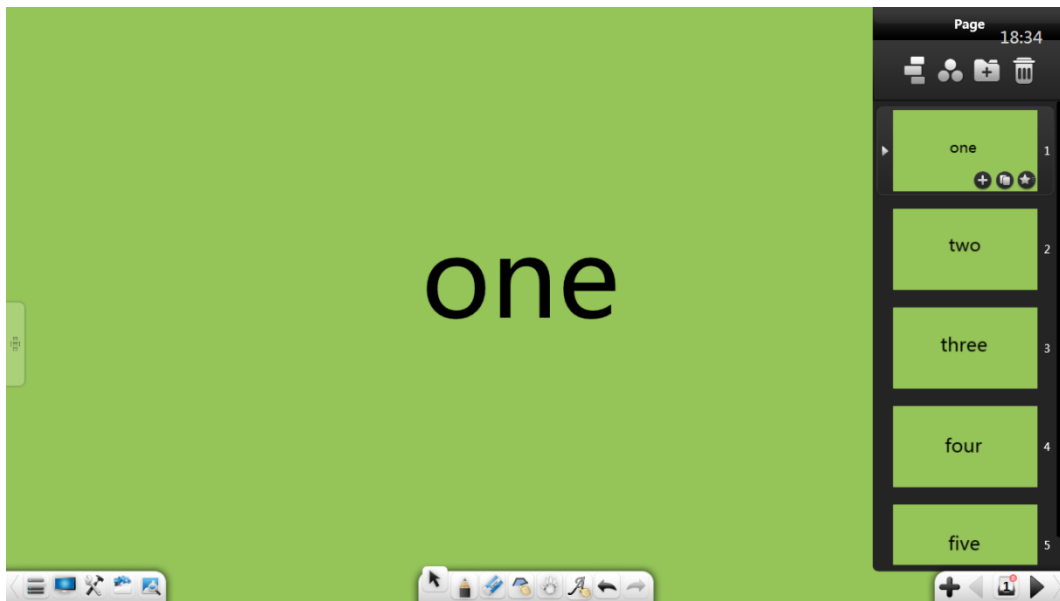

Figure 3-1-15 Page management interface

3.1.16.1 Crescent Mode

On the page management interface,  to enable the crescent browse click mode. See Figure 3-1-16-1-1.

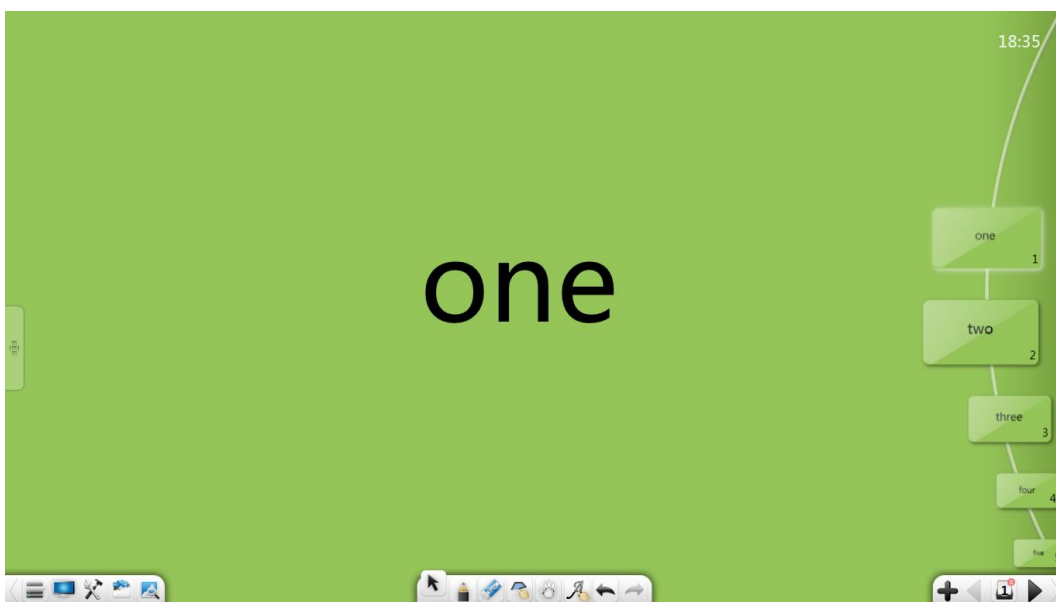

Figure 3-1-16-1-1 Page management interface

1. Browse pages: When there are many pages, you can scroll up and down to browse the thumbnails of the pages.

2. Display pages: In crescent mode, click or drag a page to display it. After the page is displayed, the crescent mode is collapsed to the rightmost of the screen. See Figure 3-1-16-1-2.

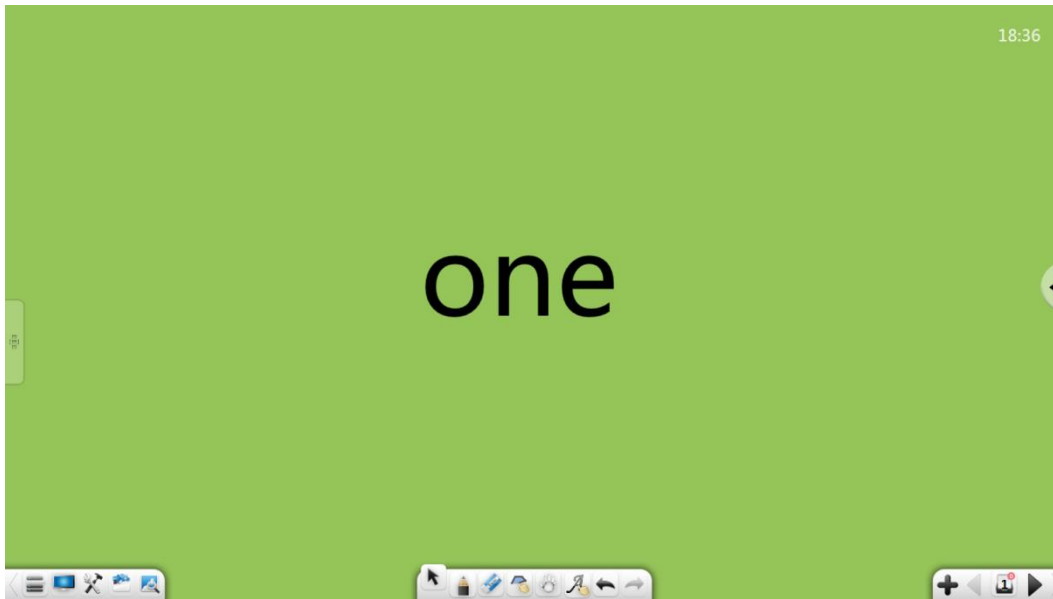





Figure 3-1-16-1-2 Page management interface

3. Show the crescent mode: Click  to show the crescent mode.
4. Exit: Click  to exit crescent mode and access the page management interface.

3.1.16.2 Page Ball Mode

Click  to enable page ball mode. Page balls can be collapsed or expanded. You can click or drag a page ball to display the corresponding page. See Figure 3-1-16-2-1. Page balls are grouped in the same way as pages.

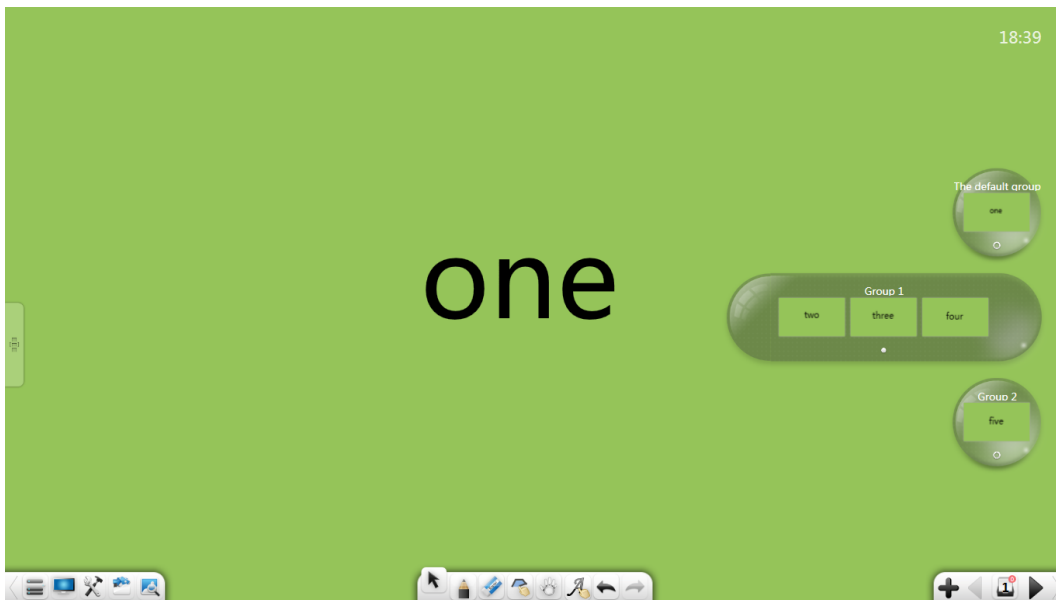





Figure 3-1-16-2-1 Page balls

1. Expand page balls: Click  to expand page balls. On an expanded page ball, you can scroll leftwards and rightwards to view page thumbnails.
2. Collapse page balls: Click  to collapse an expanded page ball.
3. Display pages: On a page ball, select a page and drag its thumbnail to the interface to display it.
4. Switching between page thumbnails: On a collapsed page ball, you can click any page thumbnail to go to the corresponding page.
5. Browse page balls: When there are many groups (page balls), you can scroll up and down to browse the page balls.
6. Exit: Click  to exit page ball mode and access the page management interface.

3.1.16.3 Page Grouping







Click  to enter the page grouping interface. You can conduct group management on the current page as required, including adding, deleting, and renaming groups, grouping and sorting pages, and collapsing and expanding pages in groups. See Figure 3-1-16-3-1.



Figure 3-1-16-3-1 Page grouping management

1. Add groups: On the grouping interface, click  to add a group.
2. Delete groups: Click  to delete a group.
3. Rename groups: Click  to rename a group.
4. Group and sort pages: Click and drag a page to any group or position.
5. Collapse/expand pages in groups: Click  to collapse an expanded group or  to expand a collapsed group.

3.1.16.4 Others

1. Delete pages: Click  to delete pages (you can delete a page or click the select all button to delete all pages. By default, the current page is

selected, as shown in Figure 3-1-16-4-1). When all pages are selected to delete, the deleted pages cannot be restored.

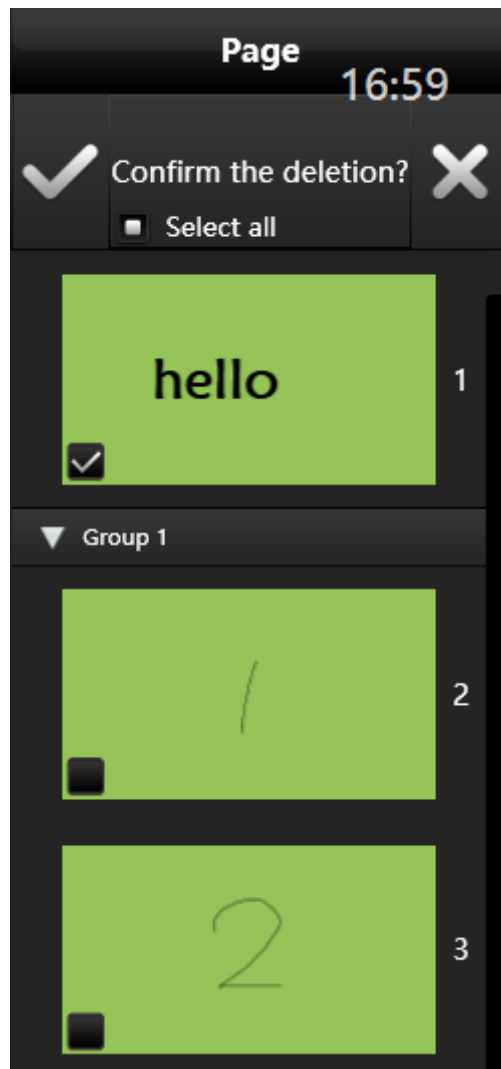





Figure 3-1-16-4-1 Deleting pages

2. Add pages: Click page.  to add a new page as the next page of the current
3. Copying pages: Click  to copy the current page on the next page (this option is unavailable when templates are used in various scenarios).
4. Special effect in page flipping: Click  to set a flipping special effect for the current page, including audio and animation effects. See Figure 3-1-16-4-2.

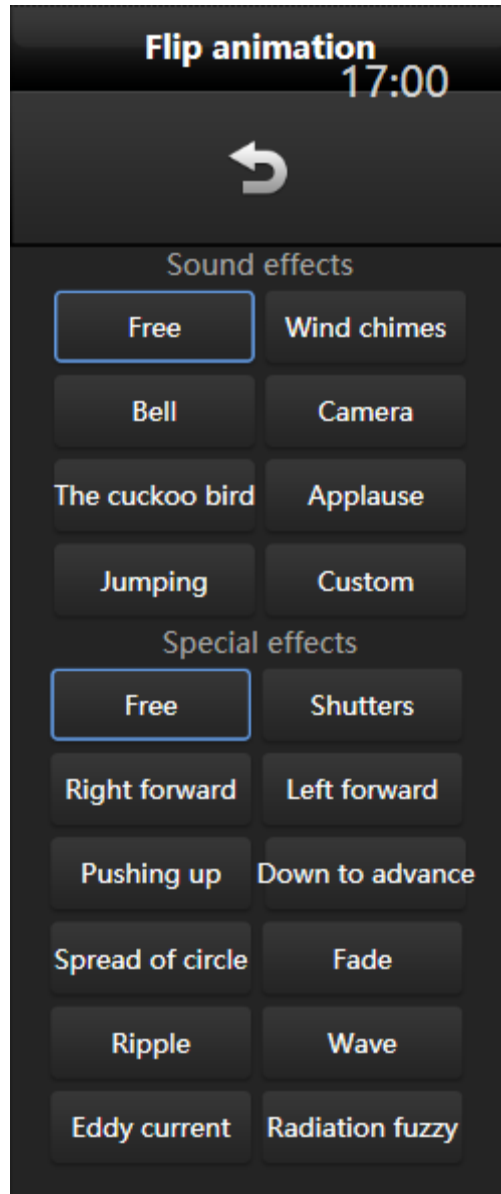

Figure 3-1-16-4-2 Special effect for page flipping

5. Browse pages: Scroll the scroll wheel up and down to browse the pages.
6. Multiplex pages: In lection preparation mode, you can drag a page to another opened program.

3.1.17 Next Page

Click  to go to the next page of the current page when the current page is not the last page.

3.1.18 Shortcuts

You can use the compound keys to call the keyboard or an external keyboard.

- Presenting mode (with toolbars): Shift+F5
- Presenting mode (without toolbars): F5
- preparation: Esc
- Selecting mode: Alt+S
- Writing mode: Alt+P
- Erasing mode: Alt+E
- Roaming mode: Alt+M
- Previous: ←/PgUp
- Next: →/PgDn
- Copy: Ctrl+C
- Paste: Ctrl+V
- Cut: Ctrl+X
- Cancel: Ctrl+Z
- Redo: Ctrl+Y
- Select all: Ctrl+A
- Cancel selection: Ctrl+D
- Insert text: Ctrl+T
- Import files: Ctrl+I
- Delete: Delete
- New: Ctrl+N
- Open: Ctrl+O
- Save: Ctrl+S



Figure 3-2 Presenting mode

3.2.1 Preparation Mode

Choose **Menu > Mode > Preparation** to switch to the preparation mode. See Figure 3-2-1. In preparation mode, you can resize the window and adjust the display proportion. Other functions are the same as those in Presenting mode.



Figure 3-2-1 preparation mode

Note:

1. In preparation mode, the text editing function is available on the toolbar.
2. In preparation mode, you can drag a picture from the browser to the software to insert the picture into a page on the software.

3. You can edit hyperlinks and animation effects only in preparation mode.

3.2.2 Presenting mode

Choose **Menu > Mode > Presenting** to switch to the Presenting mode. In the Presenting mode, the pages are displayed in full screen, and the toolbar is suspended at the bottom of the screen. The options on the toolbar from left to right include: Menu, Desktop, Treasure Chest, Resource Library, Encyclopedia, Select, Write, Eraser, Roam, Handwriting Recognition, Cancel, Redo, Previous Page, Pages, Add Page, and Next Page. For details, see section 3.1.

3.2.3 Desktop Mode

Click  to switch to the desktop mode, as shown in Figure 3-2-3-1. In the desktop mode, only the following functions are available: mouse operations, pen, eraser, tools, and returning to the Presenting mode/ preparation mode.

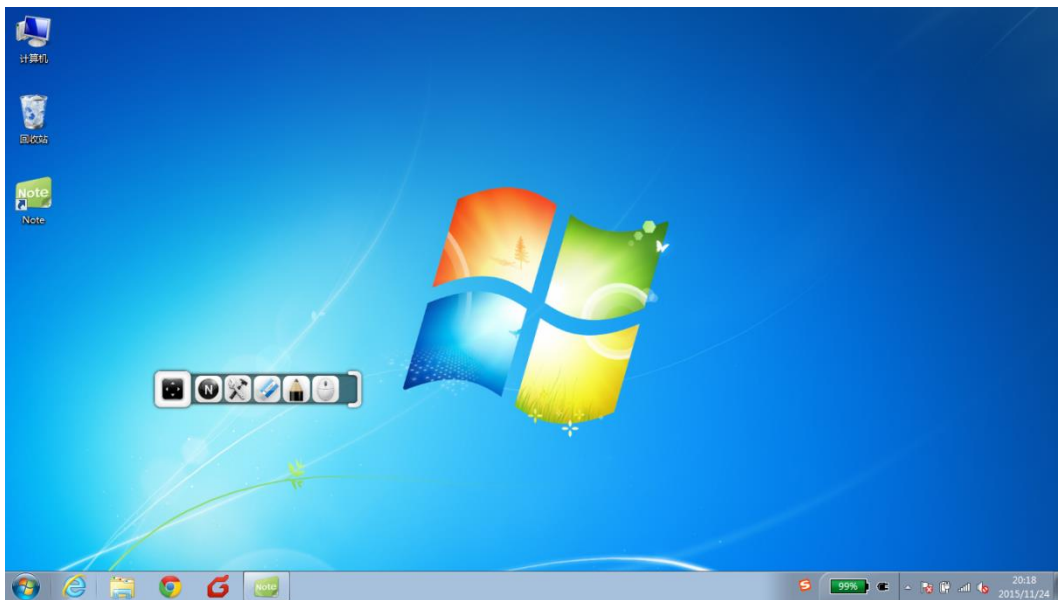



Figure 3-2-3-1 Desktop mode

1. Desktop operations: Click  to exit the comment or eraser state and return to the desktop operations.







2. Pen: Click  to enter the desktop comment state. You can use the hard-tipped pen to make comments on the current screen. Then, click  again to display the level-2 menu. You can select the color and thickness for the current hard-tipped pen, as shown in Figure 3-2-3-2.



Figure 3-2-3-2 Desktop comments

3. Eraser: Click  to erase the comments on the desktop.
4. Tools: Click  to invoke the tools such as PinP, Magnifier, Record Screen, Spotlight, Print Screen, Calendar, Clock, Screen wrap, Calculator, and Document camera. For details, see section 3.1.3.3.
5. Back: Click  to return to the full screen/ preparation mode.
6. Scale: Click  to scale the toolbar.

3.3 Subject Mode

Different scenarios are set for different subjects including English, math, chemistry, and physics. Different teaching tools are provided for different subjects. You can choose an appropriate teaching scenario based on the current subject. In each mode, click the buttons on the left of the pages to display the subject selection interface, as shown in Figure 3-3. The subject modes are mutually independent and co-exist. Only the page list of the current scenario is displayed on the page list of each subject mode. Including the standard mode, the modes can be mutually switched to each other. After the switchover of the modes, text prompt is displayed on the toolbar by default.

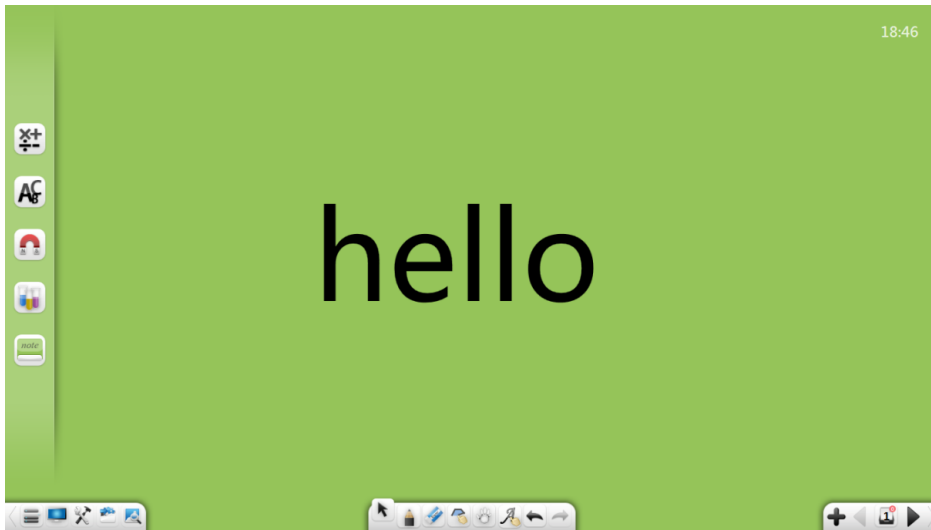



Figure 3-3 Mode switchover interface

3.3.1 Math Mode

Click  to enter the math mode, as shown in Figure 3-3-2.

14:04



Figure 3-3-1 Math mode interface

3.3.2.1 Basic Functions

In the math mode, basic math tools are provided on the toolbar, including Menu,

Desktop, Treasure Chest, Resource Library, Encyclopedia, Select, Write, Eraser, Shape, 3D Shape, Roam, Handwriting Recognition, Cancel, Redo, Previous Page, Pages, Add Page, and Next Page.

1. 3D Shape: Click  to display the 3D Shape menu, as shown in Figure 3-3-1-1. The 3D shapes include Cuboid, Triangular Pyramid, Rectangular Pyramid, Cylinder, Cone, Circular Truncated Cone, Hemisphere, Sphere, and Dihedron. By default, Cuboid is selected.

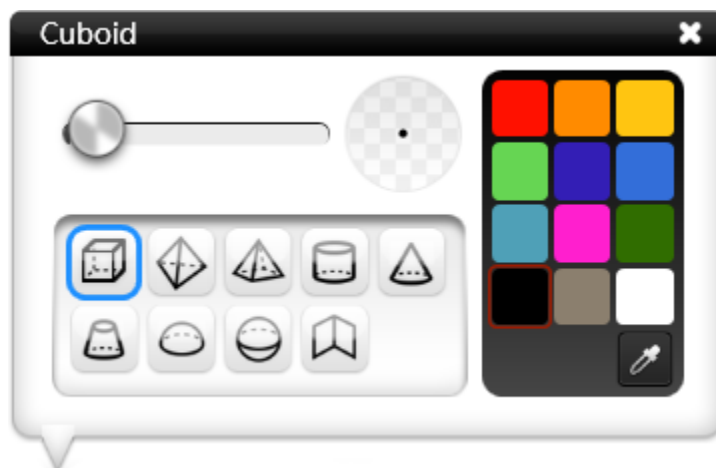





Figure 3-3-1-1 3D Shape tools

- a) Frame thickness: After you select a 3D shape type, you can slide the slider to change the thickness of frames.
- b) Color of frames: After you select a 3D shape type, you can click the color palette on the right to set the line color. There are totally 12 colors. A dropper is provided. You can select any color on the page or the color picker.

- c) Cuboid: Click  to draw a cuboid. After the drawing is completed, the cuboid is selected by default.

- d) Triangular Pyramid: Click  to draw a triangular pyramid. After the drawing is completed, the triangular pyramid is selected by default.

e) Rectangular Pyramid: Click  to draw a rectangular pyramid. After the drawing is completed, the rectangular pyramid is selected by default.

f) Cylinder: Click  to draw a cylinder. After the drawing is completed, the cylinder is selected by default.

g) Cone: Click  to draw a cone. After the drawing is completed, the cone is selected by default.

h) Circular Truncated Cone: Click  to draw a circular truncated cone. After the drawing is completed, the circular truncated cone is selected by default.

i) Hemisphere: Click  to draw a hemisphere. After the drawing is completed, the hemisphere is selected by default.

j) Sphere: Click  to draw a sphere. After the drawing is completed, the sphere is selected by default.

k) Dihedron: Click  to draw a dihedron. After the drawing is completed, the dihedron is selected by default.

2. For other functional buttons, see section 3.1.

3.3.2.2 Math Tools

Click  to display the **Treasure Chest** interface. Click the subject tools and select **Math**. The math tool interface is displayed. The tools include Mathematic Formula Recognition, Function Drawing, Compasses, Calculator, Rectilinear Scale, Triangular Plate 30°, Triangular Plate 45°, and Protractor.

3.3.2.1 Mathematic Formula Recognition



Click  to enable the Mathematic Formula Recognition tool. This tool can recognize the manually-entered mathematic formula, as shown in Figure 3-3-1-2-1. The system can automatically recognize the manually-entered mathematic formula. If a formula matching error occurs, you can manually select the corresponding part for correction. Click **Insert**. The recognized formula is inserted to the current page.

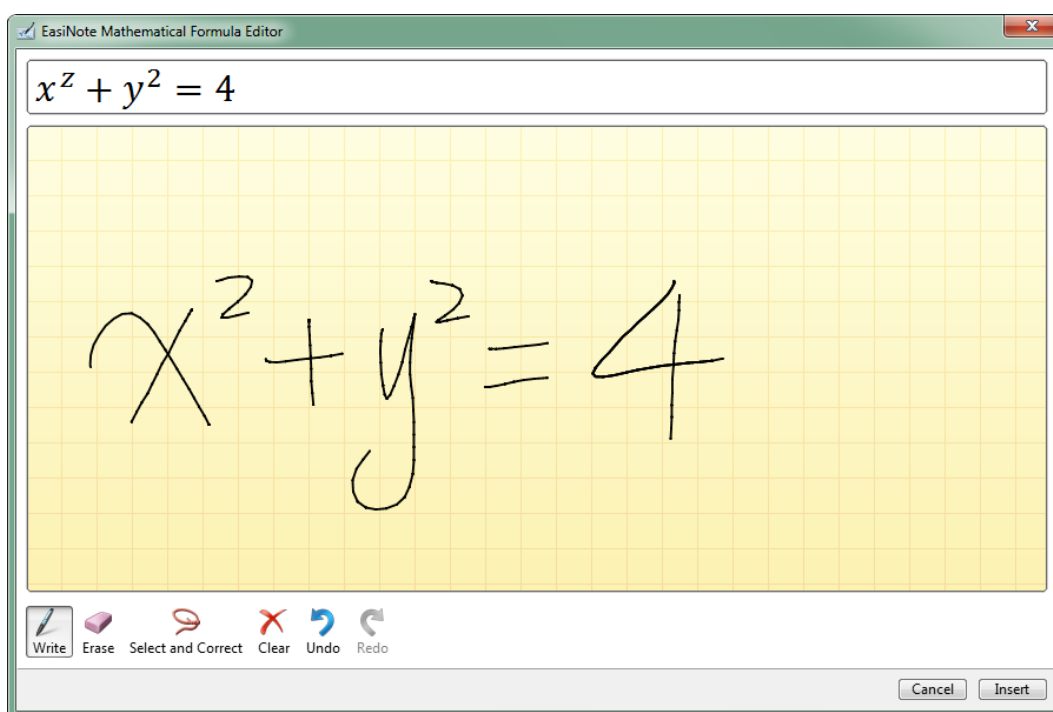



Figure 3-3-1-2-1 Handwriting formula recognition

3.3.2.2 Function Drawing



Click  to enable the function drawing tool. This tool can help you draw graphs of functions, as shown in Figure 3-3-1-2-2-1.

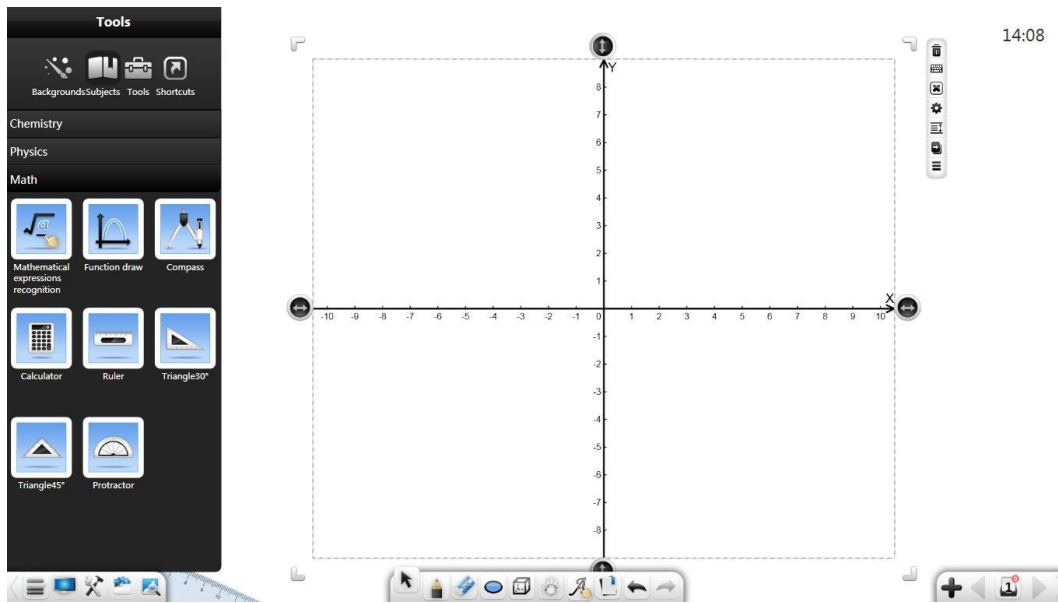

Figure 3-3-1-2-2-1 Drawing graphs of functions



1. Click  to call the mathematical function editor. By default, the editor enters the advanced function mode, as shown in Figure 3-3-1-2-2-2.



Figure 3-3-1-2-2-2 Mathematical function editor – advanced mode

- a) Enter the corresponding function keys and parameters. Click  to complete the function editing. The corresponding graph of function is automatically displayed on the number axis, as shown in Figure 3-3-1-2-2-3.

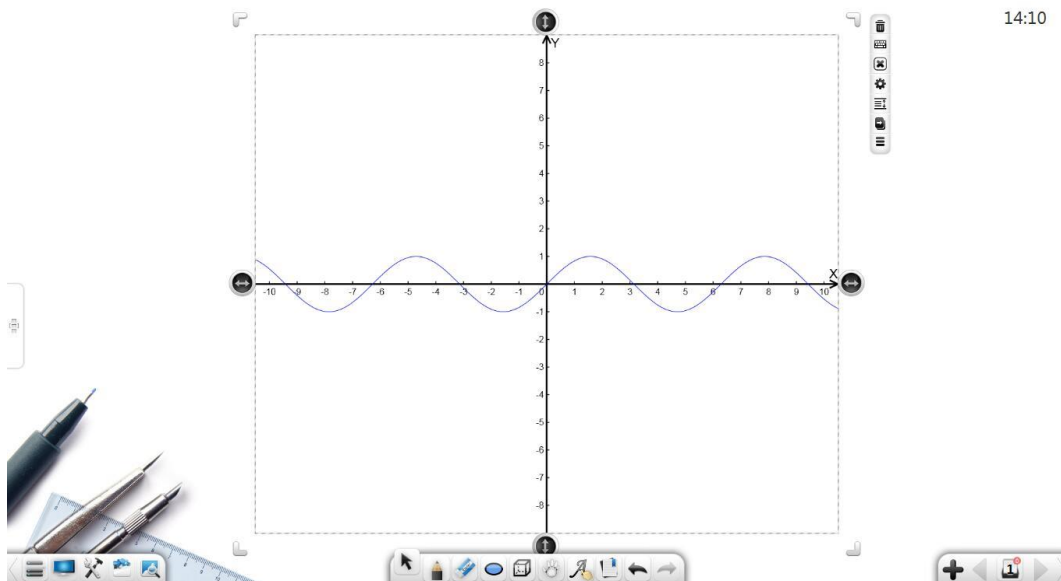

Figure 3-3-1-2-2-3 Graph of mathematical function





- b) Click  to insert a handwriting recognition formula, which is similar to the mathematical formula recognition.
- c) Drag  to the left switch over to the primary function mode, as shown in Figure 3-3-1-2-2-4. In this mode, you can directly select the corresponding simple functions.



Figure 3-3-1-2-2-4 Mathematical function editor – primary mode

- 2. Click  to delete the graph of function on the axis.
- 3. Click  to enable the mathematical coordinate system tool. The setup window is displayed, as shown in Figure 3-3-1-2-2-5.

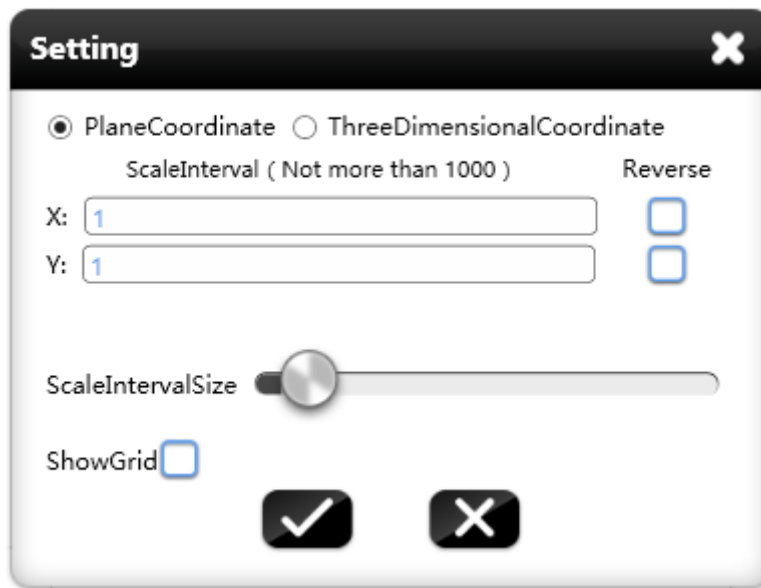

Figure 3-3-1-2-2-5 Setting the parameters of mathematical coordinate system

- a) Dimensionality: Select the plane-coordinate system or 3D coordinate system according to actual requirements.
- b) Scale interval: Set the scale interval of x, y, and z axes.
- c) Direction of coordinate axis: Select the reverse direction of the coordinate axis to switch over the positive and negative directions of the coordinate axis.
- d) Interval width: Drag the interval width icon to change the interval width of scales.
- e) Show grid: Select the Show Grid option to display the grid of the coordinates.
- f) After the settings are complete, insert the mathematical coordinate system to the whiteboard page, as shown in Figure 3-3-1-2-2-6.

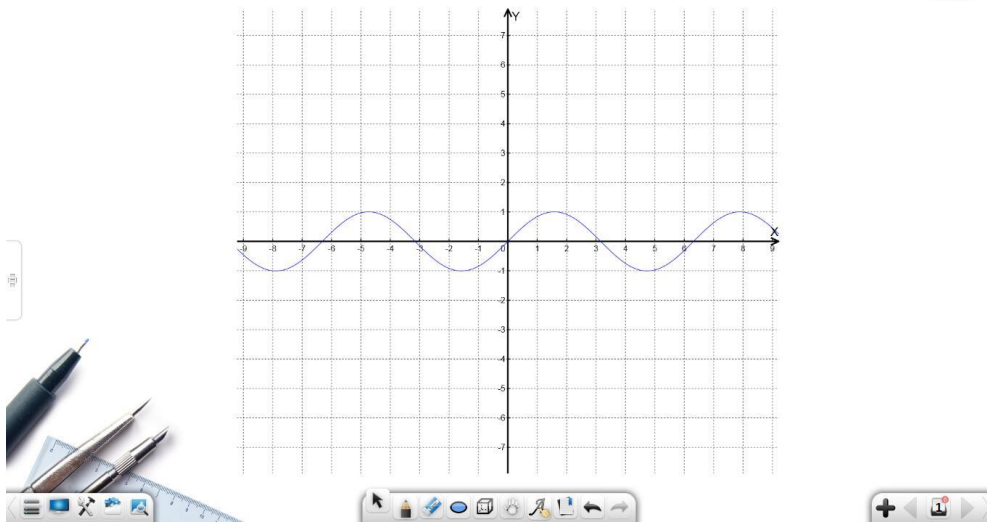







Figure 3-3-1-2-2-6 Mathematical coordinate system

4. Click and drag  or  to adjust the length of the coordinate axis.
5. Besides the above functions, you can also perform other functions such as move, delete, sort, animation effect, drag to clone, lock, combine (for multiple objects), cancel combination (multiple objects are combined), add to resource library, edit hyperlink, copy, and cut. For details, see section 3.1.6.1.

3.3.2.2.3 Compasses

Click  to enable the Compass tool, which allows you to move and rotate an object, adjust the radius, and draw the circle, arc, and sector.

1. Click  and drag the compass to move the compass.
2. Click  and drag the cuppino to adjust the radius of the circle and display the current radius length. Meanwhile, you can rotate the direction of the compass.
3. Click  to switch over the drawing effects of the compass, including the arc and sector.
4. Drag the compass to draw a circle, as shown in Figure 3-3-1-2-3.

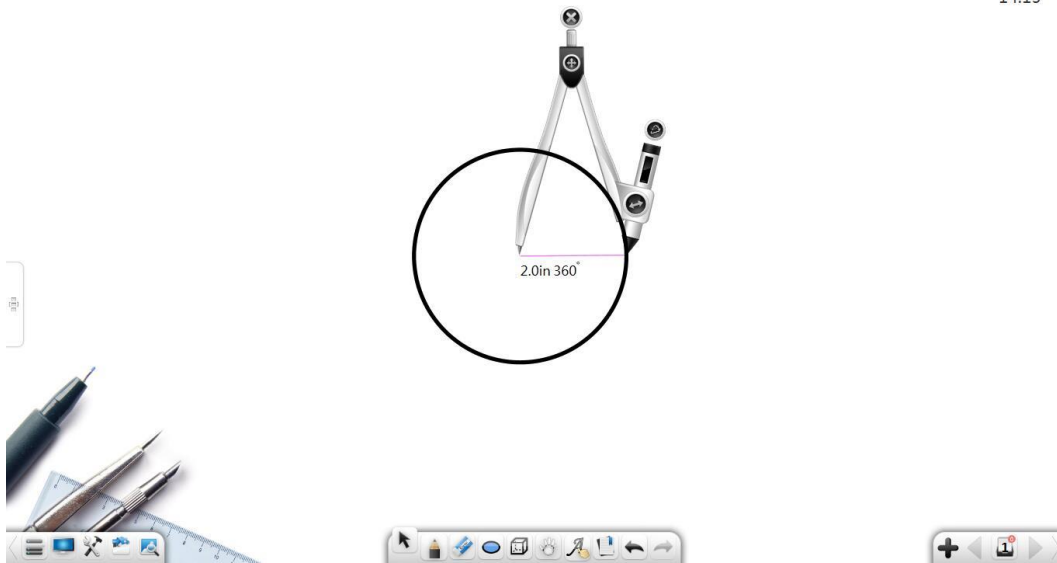



Figure 3-3-1-2-3 Drawing by using the compass

5. Click  to close the compass tool.

3.3.2.2.4 Calculator

Click  to enable the calculator tool, which allows you to do simple mathematical calculations, as shown in Figure 3-3-1-2-4.

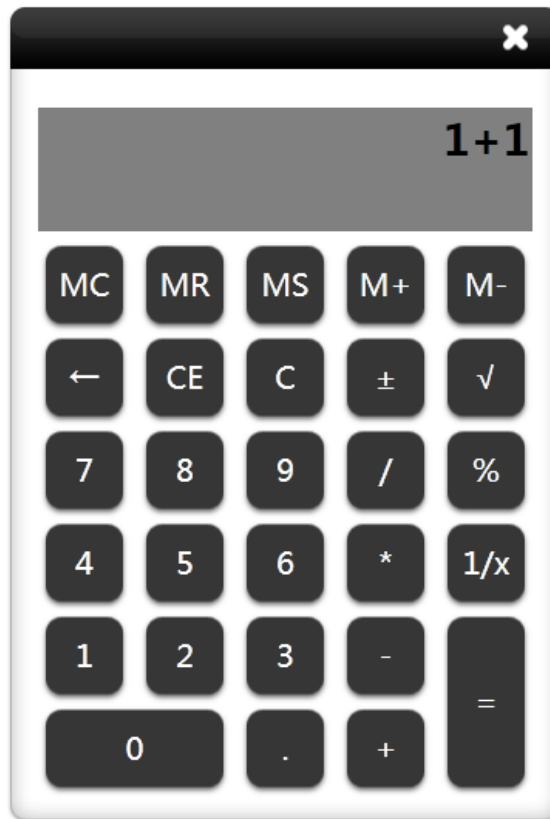



Figure 3-3-1-2-4 Calculator

3.3.2.2.5 Rectilinear Scale



Click  to enable the Rectilinear Scale tool, which allows you to draw, stretch, and rotate lines. Click the scale and drag forwards or backwards along the scale to draw a line. The length of the line is displayed in the middle part of the rectilinear scale, as shown in Figure 3-3-1-2-5.

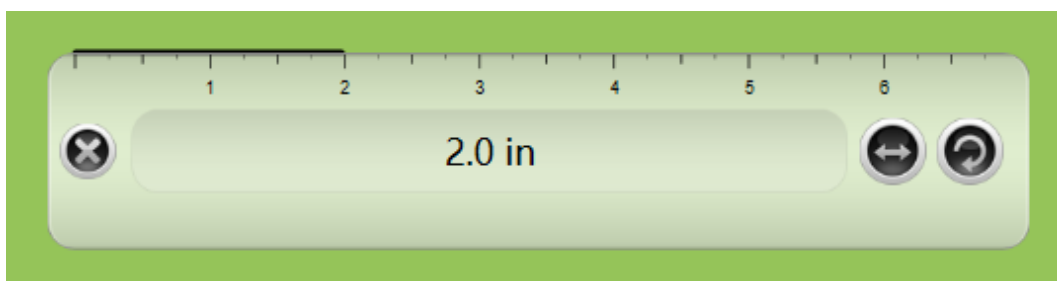



Figure 3-3-1-2-5 Drawing lines by using the rectilinear scale

3.3.2.2.6 Triangular Plate 30°

Click  to enable the Triangular Plate 30° tool, which allows you to draw, stretch, and rotate lines. The drawing operations are the same as those by using the rectilinear scale.

3.3.2.2.7 Triangular Plate 45°

Click  to enable the Triangular Plate 45° tool, which allows you to draw, stretch, and rotate lines. The drawing operations are the same as those by using the rectilinear scale.

3.3.2.2.8 Protractor

Click  to enable the protractor tool, which allows you to rotate, measuring, and drawing angles. Align two vernier scales with the sides of the angle. The protractor automatically displays the angle, as shown in Figure 3-3-1-2-8-1.

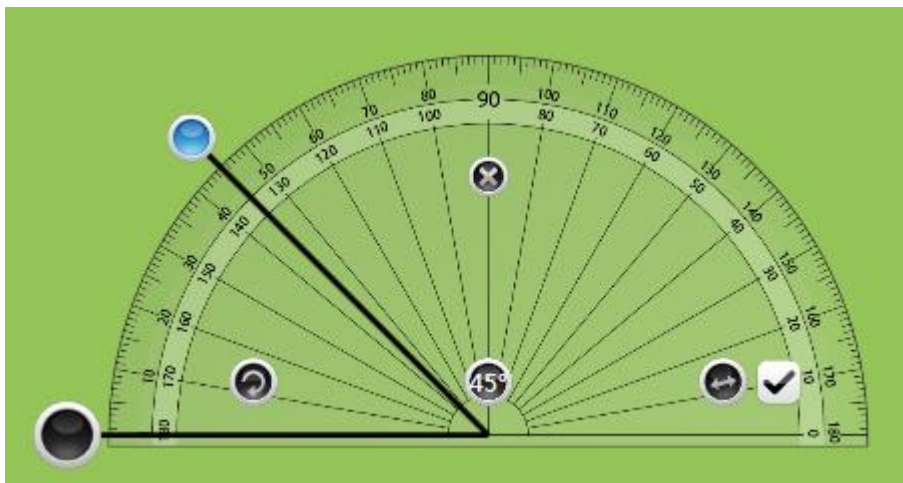



Figure 3-3-1-2-8-1 Measuring angles by using the protractor

- Drag the vernier scales to make them positioned with a certain angle. Click  to insert the formed angle to the current page, as shown in Figure 3-3-1-2-8-2. If the angle between the vernier scales is 0°, no angle is drawn by default. (Note: you can change the length of the angle by changing the length of the vernier scales.)

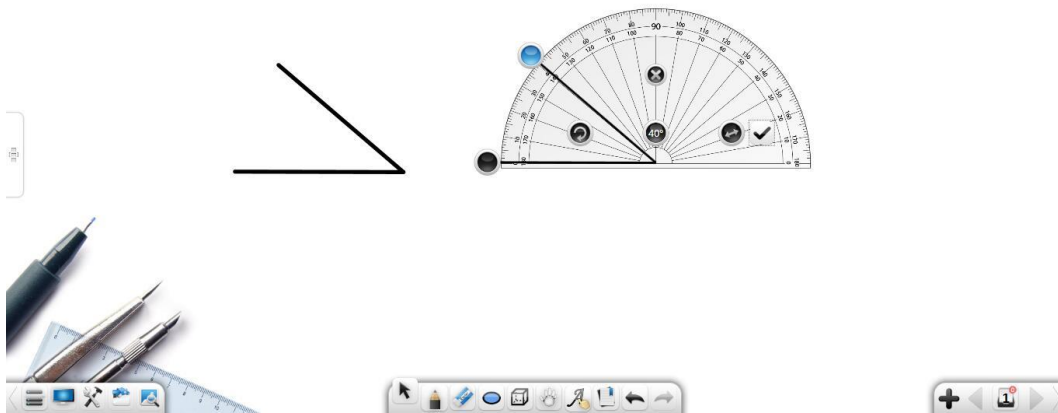



Figure 3-3-1-2-8-2 Drawing angles by using the protractor

3.3.2 English Mode

Click  to enter the English mode. The options on the toolbar from left to right include: Menu, Desktop, Treasure Chest, Resource Library, Encyclopedia, Select, Write, Eraser, Roam, Instructional Template, Cancel, Redo, Previous Page, Pages, Add Page, and Next Page, as shown in Figure 3-3-3-1.

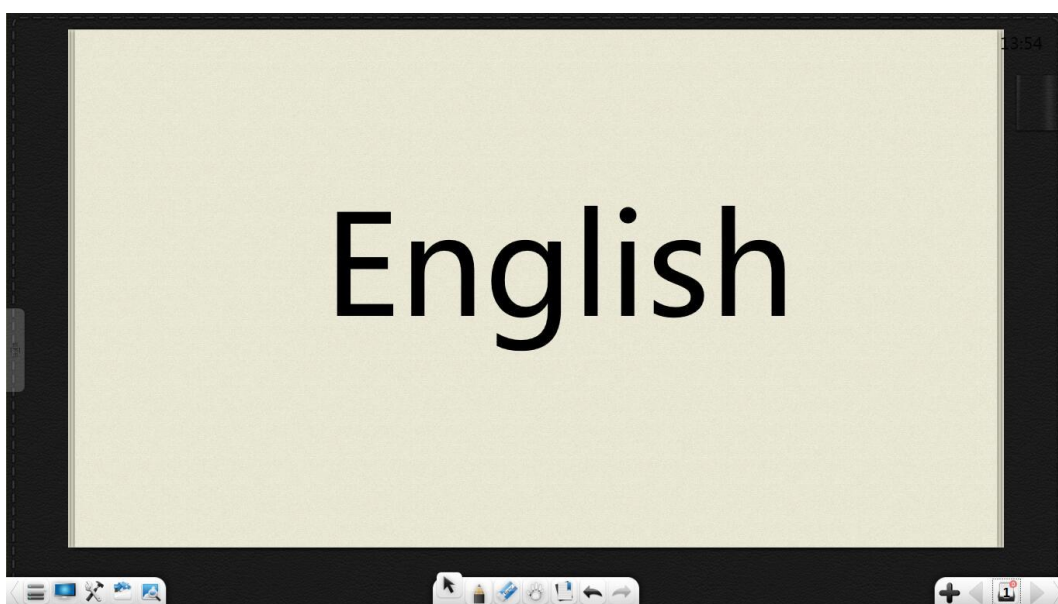



Figure 3-3-3-1 Interface in English mode

1. Click  to select the ruled paper teaching template. The ruled paper is used to demonstrate the writing of the letters. Click  and write letters. The system automatically recognizes the letters on the ruled paper, as shown in Figure 3-3-2-2.

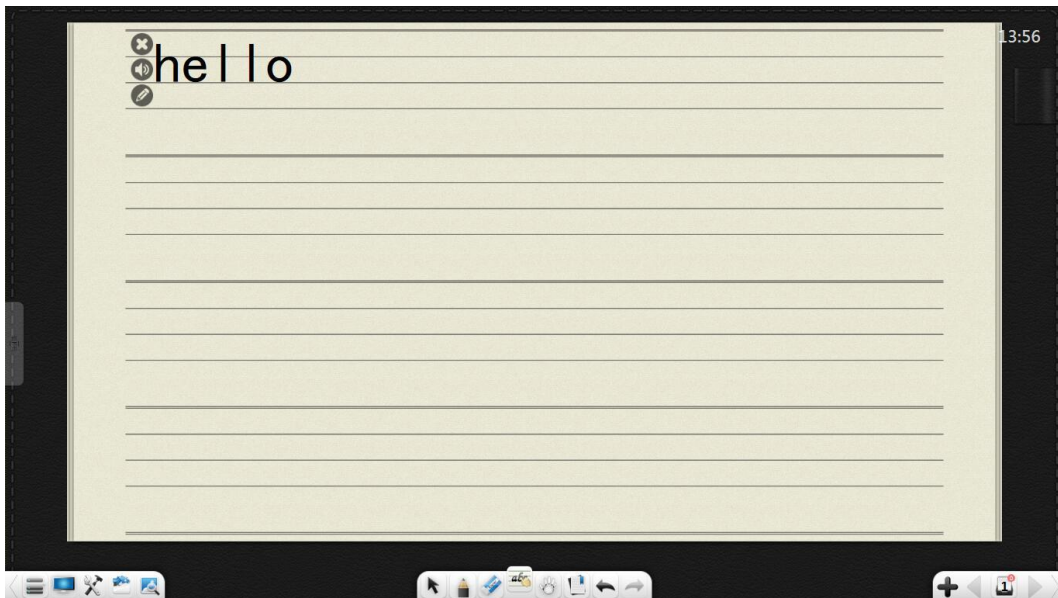





Figure 3-3-2-2 Ruled paper interface

- a) Click  to delete the entire line of letters or words on the current ruled paper.
- b) Click  to read the letters or words.
- c) Click  to re-edit the letters, as shown in Figure 3-3-2-3. For details, see section 3.3.1.1.

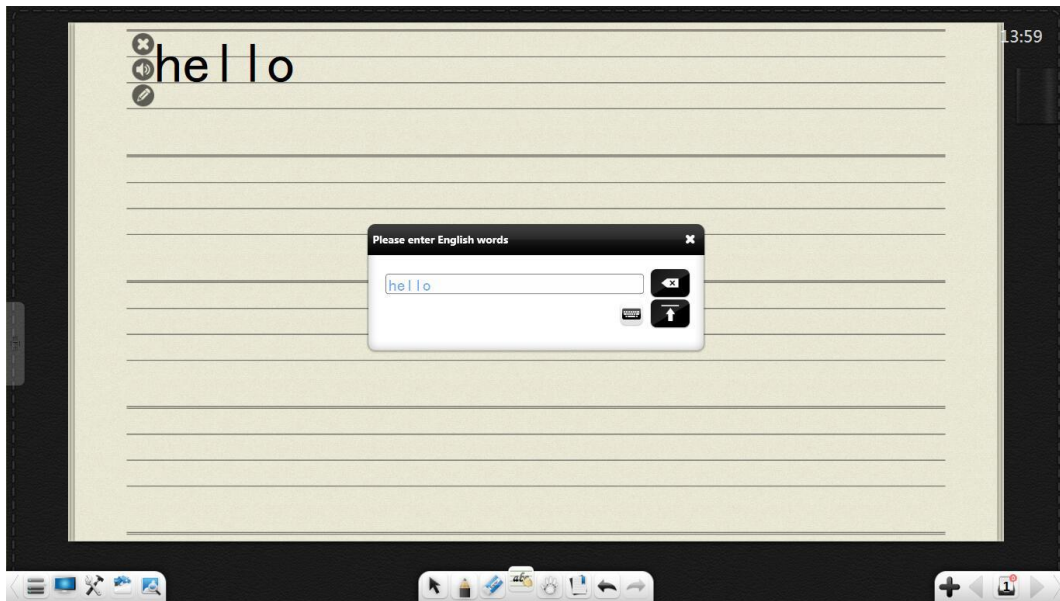



Figure 3-3-2-3 Editing letters

2. For other functional buttons, see section 3.1.

3.3.3 Physics Mode

Click  to enter the physics mode, as shown in Figure 3-3-3.

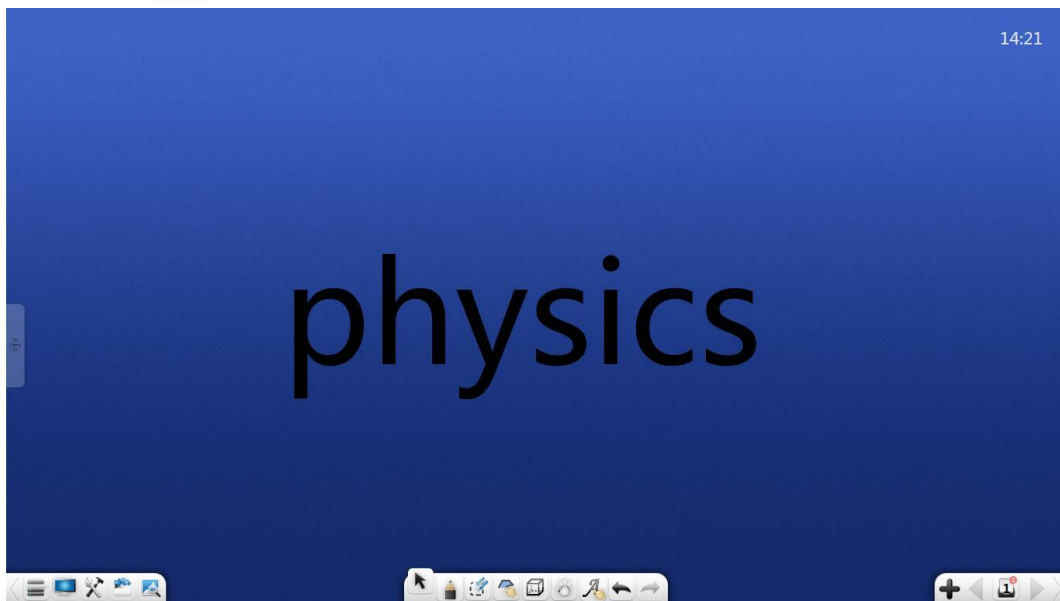

Figure 3-3-3 Physics mode

3.3.3.1 Basic Functions

In the physics mode, basic physics tools are provided on the toolbar, including Menu, Desktop, Treasure Chest, Resource Library, Encyclopedia, Select, Write,

Eraser, Shape, 3D Shape, Roam, Handwriting Recognition, Cancel, Redo, Previous Page, Pages, Add Page, and Next Page.

- The shape and 3D shape tools in Physics mode are similar to those in the Math mode. For details about other functional buttons, see section 3.1.

3.3.3.2 Physics Tools

Click  to display the **Treasure Chest** interface. Click Subject Tools and select Physics to display the physics tools interface. The options include mechanics and electricity.

3.3.3.2.1 Electricity

The electrical instruments include ammeter, bulb, power supply, power switch, voltmeter, and slide rheostat, as shown in Figure 3-3-3-2-1.

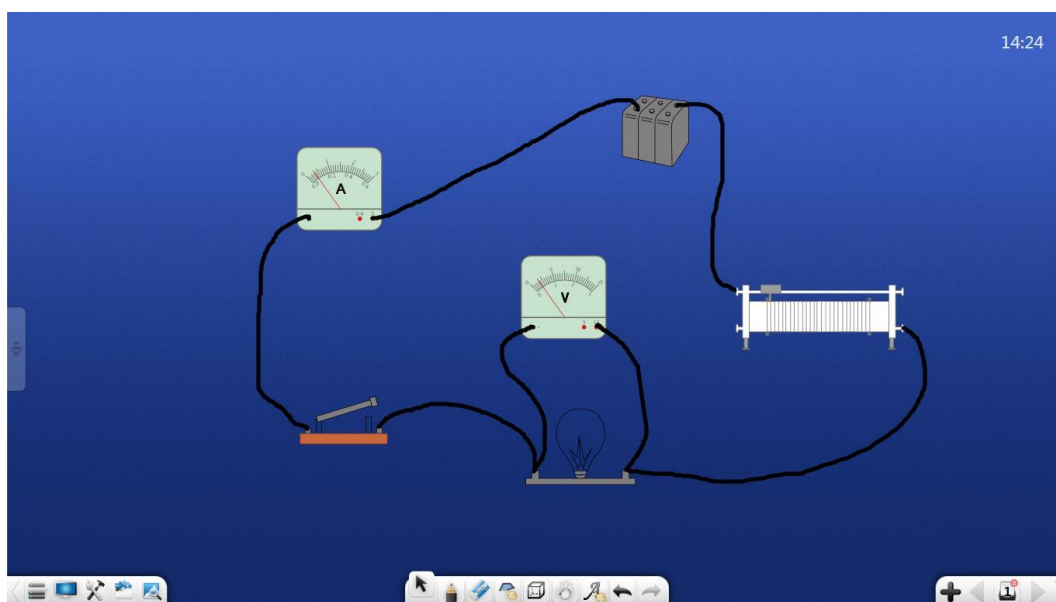





Figure 3-3-3-2-1 Electricity

1. The power instrument can be used for circuit demonstrative tests.
2. The ammeter and voltmeter can be connected to the circuit. The pointers can be adjusted to change the values.
3. The resistance of the slide rheostat can be manually adjusted.
4. The bulb can be turned on by clicking .
5. Selected power switches can be combined by clicking .

3.3.3.2 Mechanics



Click  to enter the physical resultant force mode. You can directly draw lines on the whiteboard to form the physical component forces. Two or more component forces can be automatically composed as a resultant force, as shown in Figure 3-3-3-2-2.

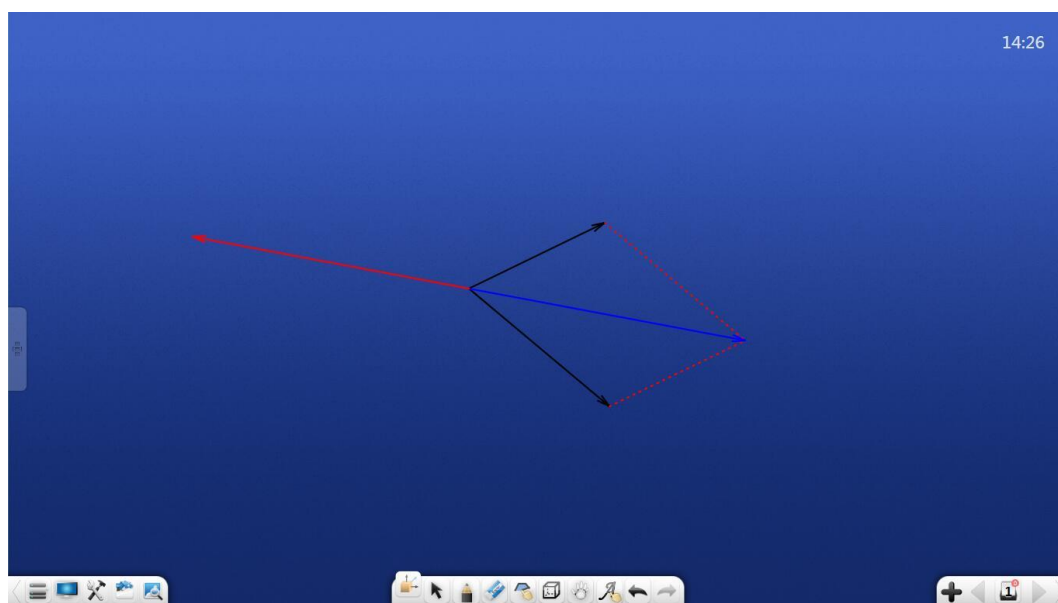

Figure 3-3-3-2-2 Physical resultant force

3.3.4 Chemistry Mode



Click  to enter the chemistry mode, as shown in Figure 3-3-4.

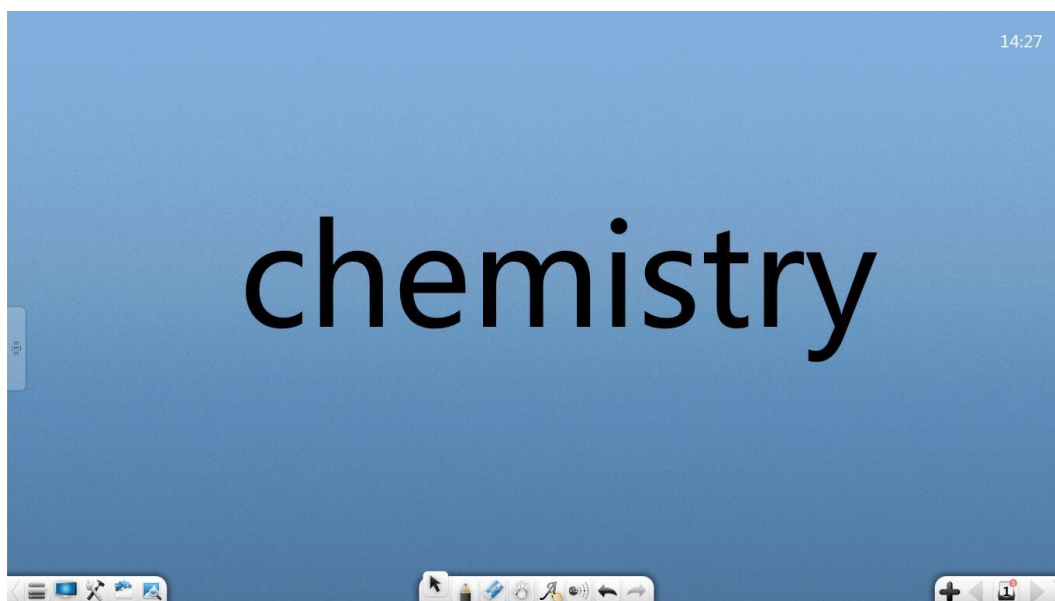



Figure 3-3-4 Chemistry mode interface

3.3.4.1 Basic Functions

In the chemistry mode, basic chemical tools are provided on the toolbar, including Menu, Desktop, Treasure Chest, Resource Library, Encyclopedia, Select, Write, Eraser, Roam, Handwriting Recognition, Chemical Formula, Atomic Structure Diagram, Cancel, Redo, Previous Page, Pages, Add Page, and Next Page.

- For details about the Chemical Formula and Atomic Structure Diagram, see section 3.3.5.2. For other functional buttons, see section 3.1.

3.3.4.2 Chemical Tools

Click  to display the **Treasure Chest** interface. Click the subject tools and select Chemistry. The chemical tools interface is displayed, including Atomic Structure Diagram, Periodic Table of Chemical Elements, Chemical Formula, and Chemical Experiment Instruments.

3.3.4.2.1 Atomic Structure Diagram

Click  to enable the chemical atomic analyzer. By default, the Calcium analyzer is enabled, as shown in Figure 3-3-4-2-1-1.

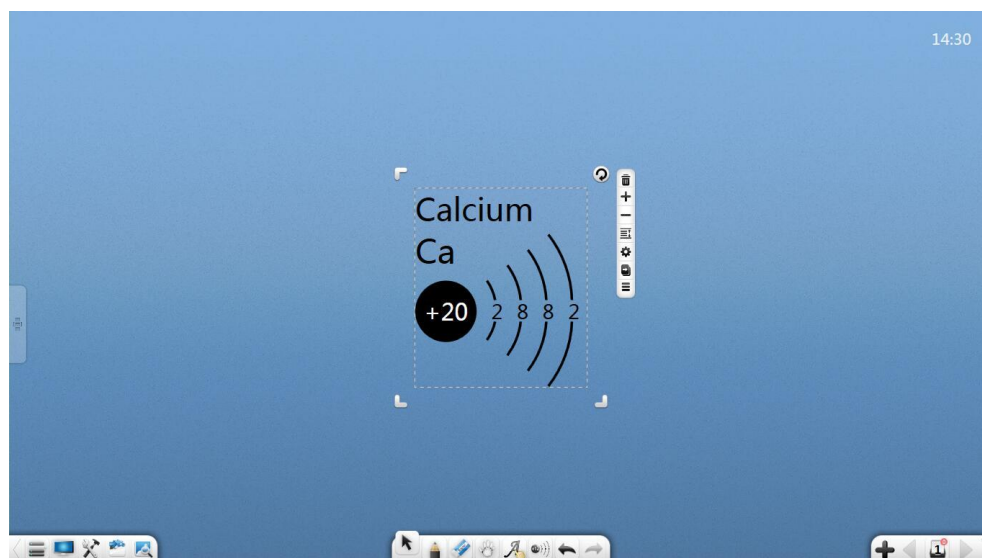





Figure 3-3-4-2-1-1 Chemical atomic analyzer

1. Click  to close the chemical atomic analyzer.
2. Click  to view the next chemical atom.
3. Click  to view the previous chemical atom.
4. Click  to select the elements from the periodic table of chemical elements. When different atoms are selected, the analyzer displays the distribution diagrams of different atoms, as shown in Figure 3-3-4-2-1-2.

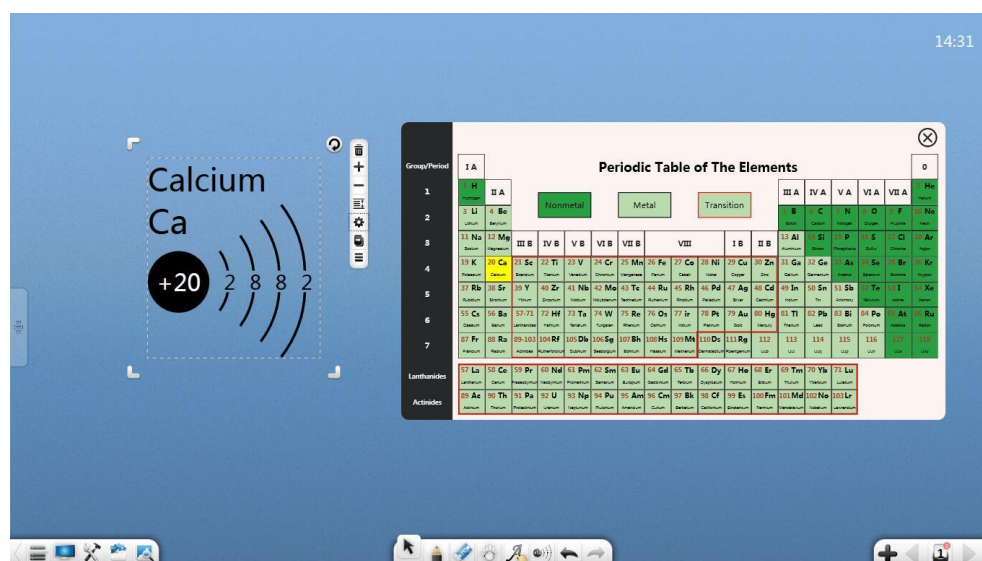

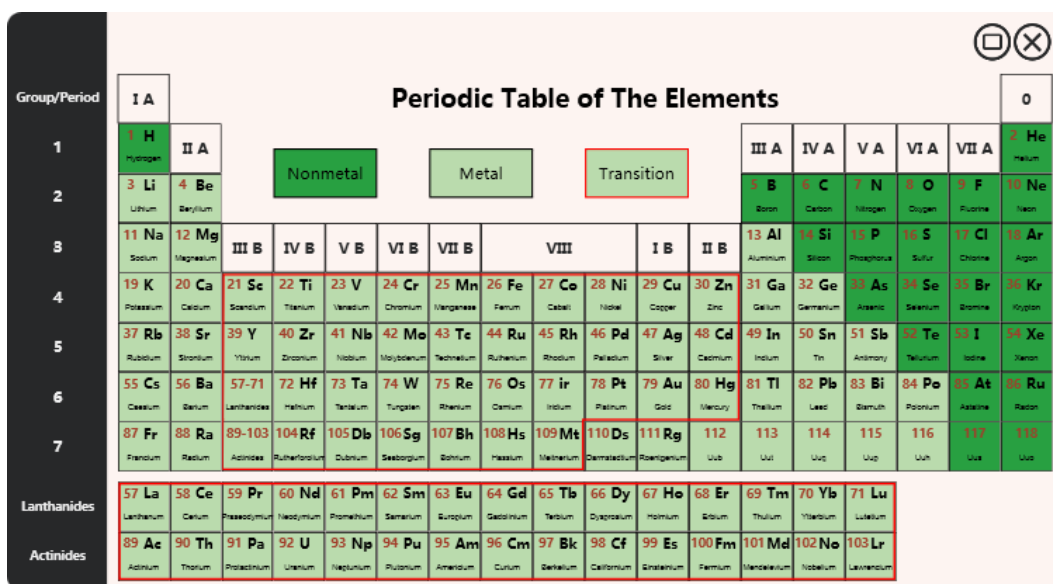

Figure 3-3-4-2-1-2 Periodic table of chemical elements

- Click  to drag the current atom to directly clone the atom.

3.3.4.2 Periodic Table of the Elements

Click  to open the periodic table of the elements, as shown in Figure 3-3-4-2-2. When you click "x", the window of the periodic table of the elements is closed. When you click "□", the periodic table of the elements is displayed in full screen. On a multi-point touch screen, you can perform the two-point zooming and moving operations.



Group/Period	IA	II A	Periodic Table of The Elements										III A	IVA	VA	VIA	VII A	0	
1	H Hydrogen																		He Helium
2	Li Lithium	Be Beryllium											B Boron	C Carbon	N Nitrogen	O Oxygen	F Fluorine	Ne Neon	
3	Na Sodium	Mg Magnesium											Al Aluminum	Si Silicon	P Phosphorus	S Sulfur	Cl Chlorine	Ar Argon	
4	K Potassium	Ca Calcium	Sc Scandium	Ti Titanium	V Vanadium	Cr Chromium	Mn Manganese	Fe Iron	Co Cobalt	Ni Nickel	Cu Copper	Zn Zinc	Ga Gallium	Ge Germanium	As Arsenic	Se Selenium	Br Bromine	Kr Krypton	
5	Rb Rubidium	Sr Strontium	Y Yttrium	Zr Zirconium	Nb Niobium	Mo Molybdenum	Tc Technetium	Ru Ruthenium	Rh Rhodium	Pd Palladium	Ag Silver	Cd Cadmium	In Indium	Sn Tin	Sb Antimony	Te Tellurium	I Iodine	Xe Xenon	
6	Cs Cesium	Ba Barium	Lanthanides		Hf Hafnium	Ta Tantalum	Tungsten	Rhodium	Cadmium	Indium	Gold	Mercury	Thallium	Lead	Bismuth	Polonium	Astatine	Ra Radium	
7	Fr Francium	Ra Radium	Actinides		Rf Rutherfordium	Db Dubnium	Sg Seaborgium	Bh Bohrium	Hs Hassium	Mt Meitnerium	Ds Darmstadtium	Rg Roentgenium	Uu Ununseptium	Uu Ununseptium	Uu Ununseptium	Uu Ununseptium	Uu Ununseptium	Uu Ununseptium	
	Lanthanides		57 La Lanthanum	58 Ce Cerium	59 Pr Praseodymium	60 Nd Neodymium	61 Pm Promethium	62 Sm Samarium	63 Eu Europium	64 Gd Gadolinium	65 Tb Terbium	66 Dy Dysprosium	67 Ho Holmium	68 Er Erbium	69 Tm Thulium	70 Yb Ytterbium	71 Lu Lutetium		
	Actinides		89 Ac Actinium	90 Th Thorium	91 Pa Protactinium	92 U Uranium	93 Np Neptunium	94 Pu Plutonium	95 Am Americium	96 Cm Curium	97 Bk Berkelium	98 Cf Californium	99 Es Einsteinium	100 Fm Fermium	101 Md Mendelevium	102 No Nobelium	103 Lr Lawrencium		

Figure 3-3-4-2-2 Main interface of the periodic table of the elements

3.3.4.2.3 Chemical Experiment Instruments

On the treasure chest page, you can drag a chemical experiment instrument among the chemical tools to demonstrate experiments.

(1) Liquid level adjustment container

The liquid level adjustment containers include test tube, beaker, conical flask, flask, distilled water tank, Kipp's apparatus, separatory funnel, acid buret, base buret, u-shaped tube, and thermometer, as shown in Figure 3-3-4-2-3-1.

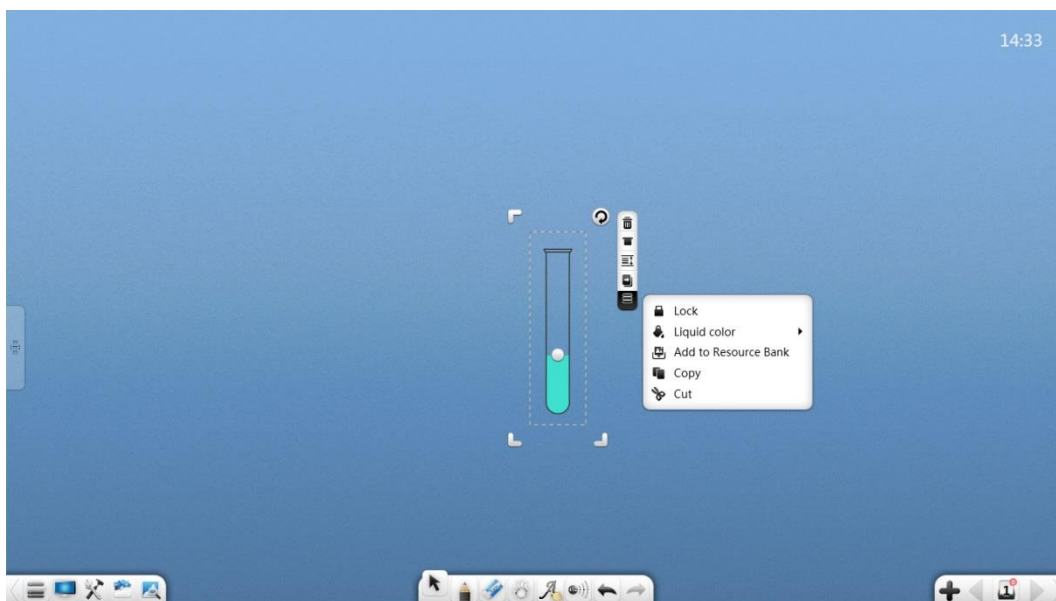



Figure 3-3-4-2-3-1 Test tube

1. The following operations: moving, select and non-uniform zooming, deletion, setting the object level, setting animation effects, dragging the object to clone it, locking, grouping (multiple objects), ungrouping, adding the object to the resource library, editing a hyperlink, copy, and cutting are similar to those in the handwriting operations. For details, see section 3.1.6.1.
2. Height of liquid level: Click and drag  above the liquid level in the container to change the height of the liquid level.
3. Rotation: Click  to rotate the container. The system can simulate the actual liquid flow according to the rotation of the container. When the inclination reaches a certain angle and the liquid level is higher than the top edge of the test tube, the liquid automatically outflows. Meanwhile, when another container is placed below the current container, the liquid can be poured into that container, as shown in Figure 3-3-4-2-3-2 (the liquid in the Kipp's apparatus, separation funnel, and thermometer do not outflow with the rotation of the container.)

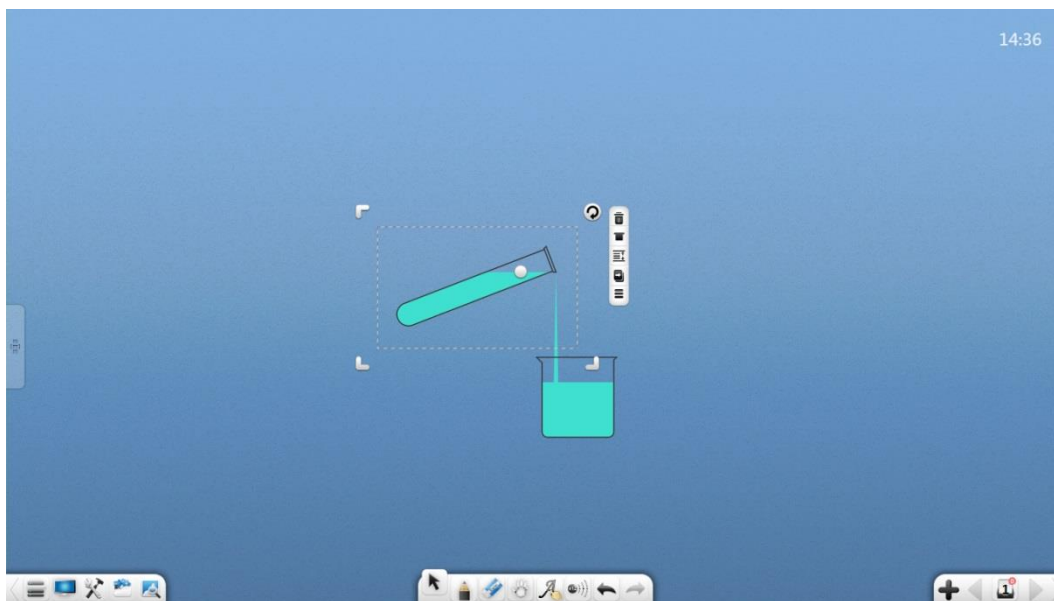



Figure 3-3-4-2-3-2 Pouring out liquid from the test tube

4. Plug: Click  to cover the container with the plug. At this time, the liquid does not outflow from the container if you rotate the container, as shown in Figure 3-3-4-2-3-3 (no plug is configured for the beaker, water channel, acid buret, and base buret).

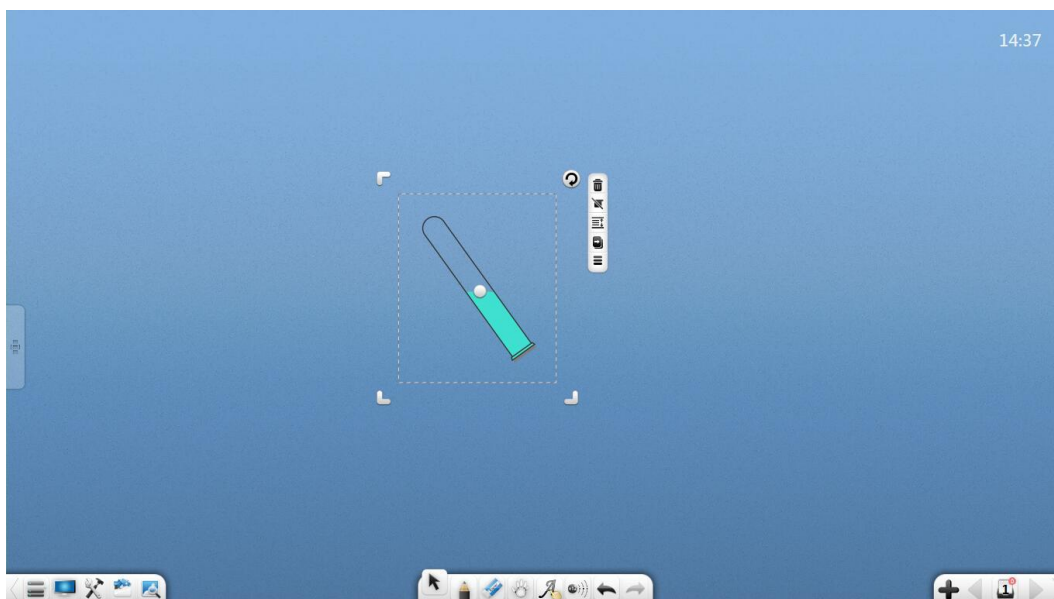

Figure 3-3-4-2-3-3 Inserting the plug into the test tube

5. Liquid color: click  to select the liquid color.

(2) Instrument stand

The instrument stand includes the test tube stand and beaker stand, as shown in Figure 3-3-4-2-3-4.

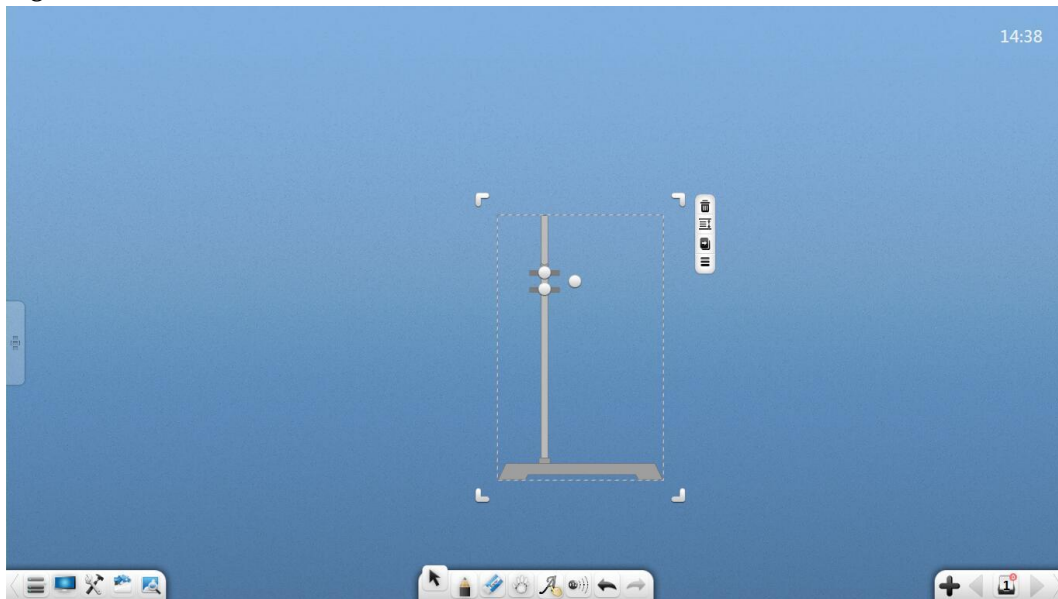



Figure 3-3-4-2-3-4 Test tube stand

1. Width of the test tube stand: Press  to adjust the width of the test tube stand.
2. Angle of inclination of the test tube clamp: Press  to adjust upwards and downwards to adjust the angle of inclination of the test tube clamp, as shown in Figure 3-3-4-2-3-5.

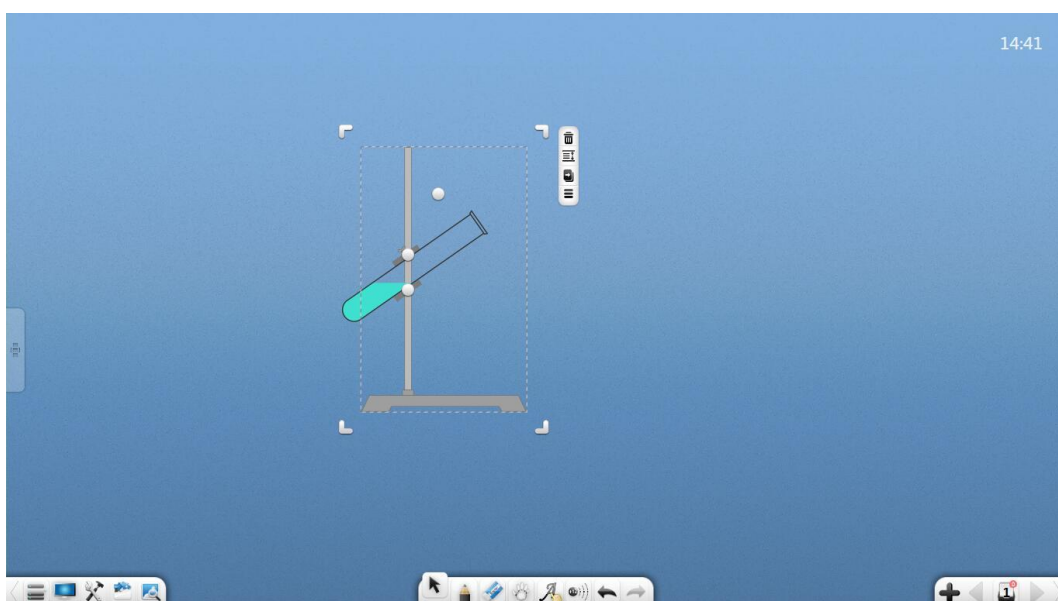





Figure 3-3-4-2-3-5 Adjusting the test tube stand

3. Beaker standard: Press  to adjust the height of the beaker mat and beaker clamp.

(3) State adjustment instruments

The state adjustment instruments include the alcohol lamp, glass pipe, and air collector.

1. Alcohol lamp: Click  to light the alcohol lamp.
2. Glass pipe: Select the glass pipe and click  to add plugs to both ends of the glass pipe.
3. Air collector: Select the air collector and click  to cover the air collector with frosted glass.

(4) Conduit

Press and drag  to adjust the length and angle of the conduit, as shown in Figure 3-3-4-2-3-6.

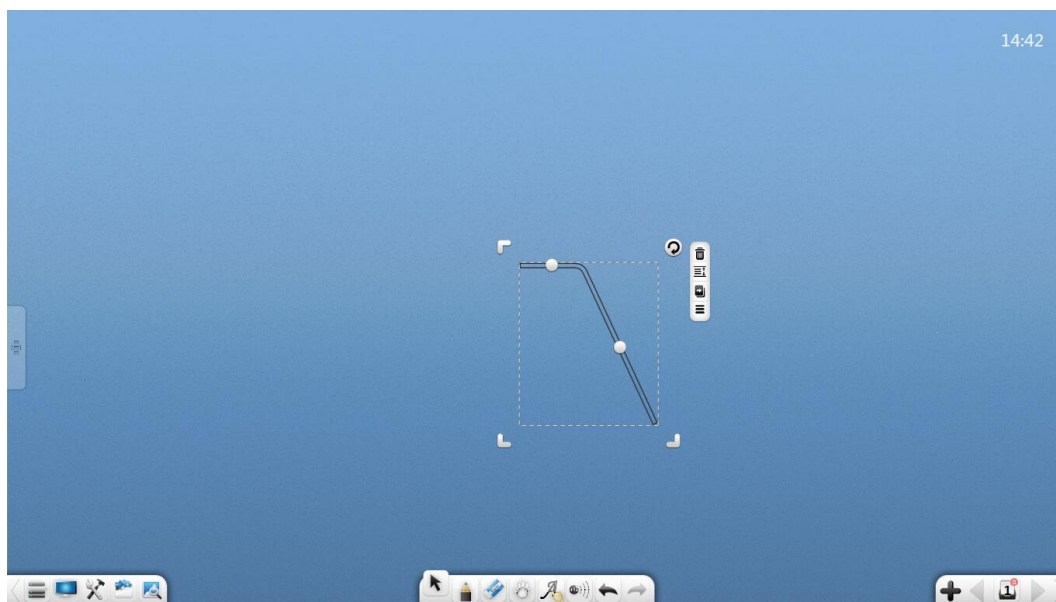

Figure 3-3-4-2-3-6 Conduit

(5) Balance

Press and drag  to adjust the balance.

(6) Others

For details about the operations of the wood bricks, horn pipe, drying pipe, condenser pipe, spherical funnel, funnel, tripod, rubber hose, and weights, see section 3.1.6.6.

Above are all the contents of the user guide of Note. The document is subject to change without notice.

Thanks for choosing our product!